

# Oilgae Guide to Algae-based Wastewater Treatment

**A Sample Report**

*Updated – April 2017*

*This e-book provides representative sample content to assist in evaluating the Oilgae Guide to Algae-based Wastewater Treatment.*

## Contact

**Oilgae**

enquiry@oilgae.com

Phone: +91 – 9952910083

The Oilgae Guide to Algae-based Wastewater Treatment is a detailed report on treating municipal and industrial wastewater using algae. This sample preview provides inputs on the focus areas of the report, the complete list of contents, and sample data from the report.

The Oilgae Guide to Algae-based Wastewater Treatment was last updated in month of April, 2017.

**Oilgae – Home of Algal Energy**

To order a copy of the report, visit - <https://secure.clixoo.com/purchase/oilgae/wwt/report.html>

## Preface to the Report

Algae are important bioremediation agents, and are already being used by many wastewater facilities. The potential for algae in wastewater remediation is however much wider in scope than its current role.

*The Oilgae Guide to Algae-based Wastewater Treatment* was prepared by Oilgae ([www.oilgae.com](http://www.oilgae.com)) as a response to the tremendous need in the market for a detailed resource that provides a compendium of case studies, practical data and insights for algae-based wastewater treatment efforts worldwide.

The focus of the report is to provide guidance that can facilitate actions on the part of the commercial sector as well as the academia and researchers. Hence, inputs and data that have been provided have slanted towards real life case studies and experiments.

While the thrust of the report is on wastewater bioremediation using algae, the report also provides detailed references on deriving biofuels from algae. Algae are currently researched for their ability to be the potential feedstock for biofuels. Combining algae biofuels with wastewater remediation provides significant economic synergies for the process.

*The Oilgae Guide to Algae-based Wastewater Treatment* will be an invaluable resource for the effluent treatment plants and sewage treatment plants at companies and communities, who are seeking expert intelligence on using algae for wastewater remediation.

This guide has been prepared by Oilgae ([www.oilgae.com](http://www.oilgae.com)), the leader in information and industry research support for the global algae-fuel industry.

*For more information, contact [enquiry@oilgae.com](mailto:enquiry@oilgae.com)*

**Oilgae – Home of Algal Energy**

To order a copy of the report, visit - <https://secure.clixoo.com/purchase/oilgae/wwt/report.html>

### Who Will Most Benefit from this Guide?

While a diverse range of industries will benefit from this report, the ETP and Sewage Treatment Plants at the following industries will benefit most from the report:

1. Meat and Poultry
2. Pulp and Paper
3. Textiles Dyeing
4. Metal Finishing
5. Dyes & Pigments
6. Distillery & Breweries
7. Pharmaceutical
8. Food & Dairy
9. Biotechnology
10. Starch & Cellulose
11. Pesticides & Insecticides
12. Chemical & Drug Formulation Units
13. Fertilizers

**This is the only report that provides comprehensive insights into the use of algae in the industrial effluent treatment plants and in sewage treatment.**

**Oilgae – Home of Algal Energy**

To order a copy of the report, visit - <https://secure.clixoo.com/purchase/oilgae/wwt/report.html>

# List of Contents

## 1. Wastewater Treatment - Concepts

- 1.1. Introduction
- 1.2. Current Wastewater Treatment Practices
- 1.3. Problems with Current Practices
- 1.4. Where Do Algae Play a Role
- 1.5. Algae-based Wastewater Treatment vs. Traditional Methods

## 2. Municipal Wastewater Treatment Using Algae

- 2.1. Introduction
- 2.2. Composition of Municipal Wastewater
- 2.3. Algae Strains that Grow Well in Municipal wastewater
- 2.4. Algae-based Municipal Wastewater Treatment Process
  - 2.4.1. Nitrogen Removal by Algae
  - 2.4.2. Phosphorous Removal by Algae
  - 2.4.3. Pathogen Removal by Algae
- 2.5. Algae-based Treatment Systems - Design and Construction
  - 2.5.1. Waste Stabilization Pond Systems
  - 2.5.2. High Rate Algal Pond Systems
  - 2.5.3. High Rate Algal Pond and Waste Stabilization Pond System – A comparison
- 2.6. Advantages of Phycoremediation of Municipal wastewater
- 2.7. Disadvantages of Phycoremediation of Municipal Wastewater
- 2.8. Cost and Economics
  - 2.8.1. Key Issues for Cost Effective Wastewater Phycoremediation
  - 2.8.2. Exploiting the Value of End-products and Processes
  - 2.8.3. Indicative Cost-Benefit Analysis for Algae-based Municipal Wastewater Treatment
- 2.9. Case Studies Research & Updates

## 3. Industrial Effluent Treatment Using Algae

- 3.1. Introduction
  - 3.1.1. Roles of Algae in Industrial and Municipal Wastewater Treatment - Similarities and Differences
  - 3.1.2. Conventional Industrial Wastewater and Treatment Methods - A Description
- 3.2. Composition of Major Industrial Effluents
- 3.3. Algal Strains Used in Various Industrial Effluent Treatments
- 3.4. Algae-based Effluent Treatment Plant for Industrial Wastewater
- 3.5. Algae-based Industrial Wastewater Treatment - Design and Construction

**Oilgae – Home of Algal Energy**

To order a copy of the report, visit - <https://secure.clixoo.com/purchase/oilgae/wwt/report.html>

- 3.6. Industry Specific Algae-based Wastewater Treatment
    - 3.6.1. Poultry Industry
    - 3.6.2. Dairy Industry
    - 3.6.3. Aquaculture Industry
    - 3.6.4. Textile Industry
    - 3.6.5. Paper and Pulp Industry
    - 3.6.6. Distillery and Brewery Industry
    - 3.6.7. Leather Processing
    - 3.6.8. Food Processing Industry
    - 3.6.9. Petrochemical Industry
    - 3.6.10. Pharmaceuticals
    - 3.6.11. Chemical Industry
    - 3.6.12. Mining Industry
    - 3.6.13. Metal Working
  - 3.7. Advantages of Industrial Wastewater Treatment Using Algae
  - 3.8. Disadvantages of Industrial Wastewater Treatment Using Algae
  - 3.9. Cost of Industrial Wastewater Treatment Using Algae
  - 3.10. Case Studies
  - 3.11. Research & Experiments
- 
4. **Nutrients Requirements of Algae**
    - 4.1. Introduction
    - 4.2. Carbon Requirements
    - 4.3. Nitrogen Requirements
    - 4.4. Phosphorus Requirements
    - 4.5. Requirements of Micronutrients
- 
5. **Harvesting of Algae from HRAP**
    - 5.1. Introduction
    - 5.2. Sedimentation
    - 5.3. Flotation
      - 5.3.1. Dissolved Air Flotation
      - 5.3.2. Suspended Air Flotation (SAF)
    - 5.4. Filtration
    - 5.5. Chemical Precipitation

Oilgae – Home of Algal Energy

To order a copy of the report, visit - <https://secure.clixoo.com/purchase/oilgae/wwt/report.html>

## **6. End Uses of Algae Grown in Wastewater**

- 6.1. Introduction
- 6.2. Various End Uses Considered For Algae Grown in Wastewater
- 6.3. Fuel Applications of Wastewater Grown Algae
  - 6.3.1. Biodiesel
  - 6.3.2. Ethanol
  - 6.3.3. Hydrogen
  - 6.3.4. Methane
  - 6.3.5. Power Generation
  - 6.3.6. Other Hydrocarbons
- 6.4. Non-fuel Applications of Wastewater Grown Algae
  - 6.4.1. Animal & Fish Feed
  - 6.4.2. Chemicals & Fertilizers
  - 6.4.3. Other Non-fuel Applications of Algae

## **7. Challenges Associated with Growing Algae in Wastewater**

- 7.1. Introduction
- 7.2. Factors Affecting Microalga Culture in HRAP & WSP
- 7.3. Challenges Associated With Algae-based Wastewater Treatment Systems

## **8. Companies in the Algae - based Wastewater Industry**

- 8.1. Introduction
- 8.2. Company Profiles

## **9. Algae Cultivation in Wastewater - Q&A**

## **10. References**

- 10.1. Algal Biomass Organizations
- 10.2. Universities in Algae-based Wastewater Treatment Research
- 10.3. Wastewater Treatment - Current Trends

# 1

## Wastewater Treatment Concepts

This chapter will provide a clear understanding about the critical role of algae in wastewater treatment, and also provides inputs on advantages of algae-based wastewater treatment over the traditional methods used.

### 1.1 Introduction

### 1.2 Current Wastewater Treatment Practices

### 1.3 Problems with Current Practices

### 1.4 Where Do Algae Play a Role?

### 1.5 Algae-based Wastewater Treatment vs. Traditional Methods

#### Sample Content: Problems with Current Practices

The major disadvantages associated with current wastewater treatment practices are:

- Many wastewater treatment processes generate large amounts of sludge that must be sent off-site for disposal. Handling and disposal of this sludge is typically the largest single cost component in the operation of a wastewater treatment plant.
- Most wastewater treatment processes cannot effectively respond to diurnal, seasonal, or long-term variations in the composition of wastewater. A treatment process that may be effective in treating wastewater during one time of the year may not be as effective at treating wastewater during another time of the year.
- High energy requirements will make many wastewater treatment methods unsuitable for low per-capita energy consumption countries.
- High operation and maintenance requirements, including production of large volumes of sludge (solid waste material), make them economically unviable for many regions.

Oilgae – Home of Algal Energy

To order a copy of the report, visit - <https://secure.clixoo.com/purchase/oilgae/wwt/report.html>



## Sample Content: Where Do Algae Play a Role?

*Conventional Wastewater Treatment Vs Algae-based Wastewater Treatment*

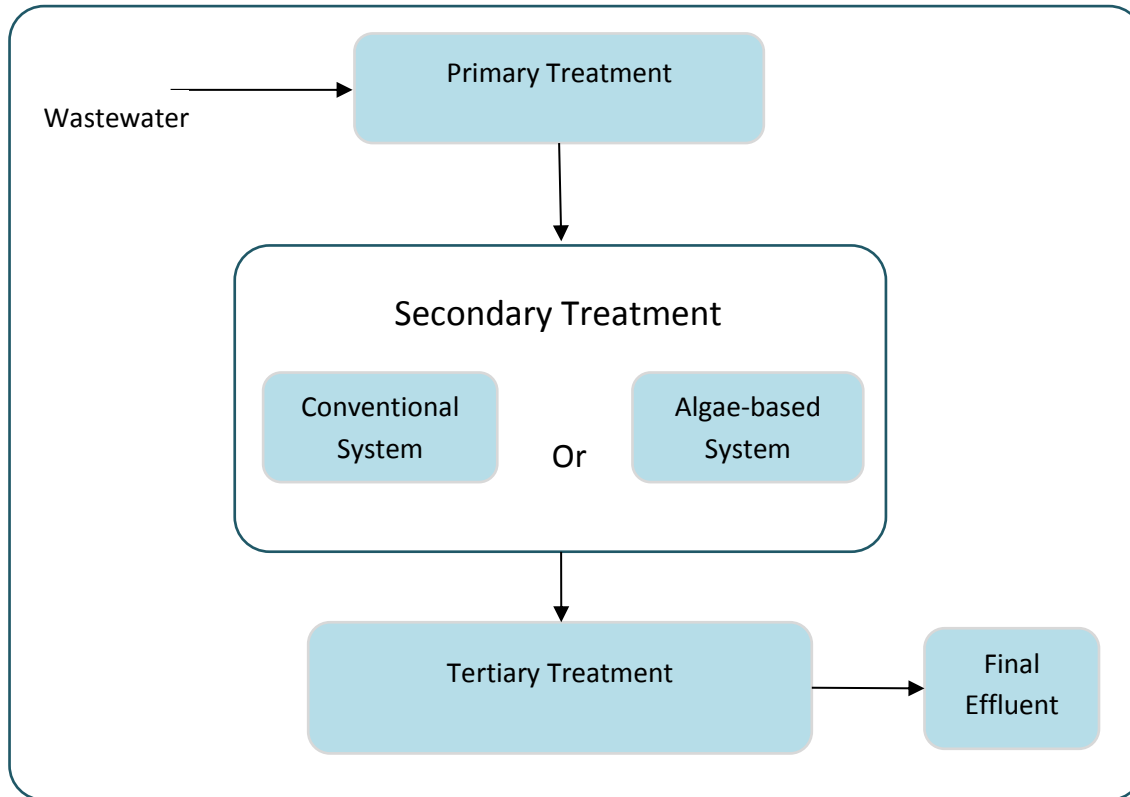

## Sample Content: Algae-based Wastewater Treatment vs. Traditional Methods

Using algae for wastewater treatment offers some interesting advantages over conventional wastewater treatment.

### *Advantages of algae wastewater treatment*

- Cost effective
- Low energy requirement
- Reductions in sludge formation
- GHG emission reduction
- Production of useful algal biomass

**Oilgae – Home of Algal Energy**

To order a copy of the report, visit - <https://secure.clixoo.com/purchase/oilgae/wwt/report.html>

- *Cost Effective* - It has been shown to be a more cost effective way to remove biochemical oxygen demand, pathogens, phosphorus and nitrogen than activated sludge process and other secondary treatment processes (Green et al., 1996).
- *Low Energy Requirements* - Traditional wastewater treatment processes involve the high energy costs of mechanical aeration to provide oxygen to aerobic bacteria to consume the organic compounds in the wastewater, whereas in algae based wastewater treatment, algae provides the oxygen for aerobic bacteria. Aeration is an energy intensive process, accounting for 45 to 75% of a wastewater treatment plant's total energy costs. Algae provide an efficient way to consume nutrients and provide the aerobic bacteria with the needed oxygen through photosynthesis. Roughly one kg of BOD removed in an activated sludge process requires one kWh of electricity for aeration, which produces one kg of fossil CO<sub>2</sub> from power generation (Oswald, 2003). By contrast, one kg of BOD removed by photosynthetic oxygenation requires no energy inputs and produces enough algal biomass to generate methane that can produce one kWh of electric power (Oswald, 2003).
- *Reductions in Sludge Formation* - In conventional wastewater treatment systems the main aim is to minimize or eliminate the sludge. Industrial effluents are conventionally treated using a variety of hazardous chemicals for pH correction, sludge removal, colour removal and odour removal. Extensive use of chemicals for effluent treatment results in huge amounts of sludge which forms the so called hazardous solid waste generated by the industry and finally disposed by depositing them in landfills. In algae wastewater treatment facilities, the resulting sludge with algal biomass is energy rich which can be further processed to make biofuel or other valuable products such as fertilizers. Algal technology avoids use of chemicals and the whole process of effluent treatment is simplified. There is considerable reduction in sludge formation.
- *The GHG Emission Reduction* – The US Environmental Protection Agency (EPA) has specifically identified conventional wastewater treatment plants as major contributors to greenhouse gases. Algae based wastewater treatment also releases CO<sub>2</sub> but the algae consume more CO<sub>2</sub> while growing than that is being released by the plant, this makes the entire system carbon negative.
- *Production of Useful Algal Biomass* – The resulting algae biomass is a source of useful products such as biodiesel. Previous research in the early 1990's by the National Renewable Energy Laboratory (NREL) showed that under controlled conditions algae are capable of producing 40 times the amount of oil for biodiesel per unit area of land, compared to terrestrial oilseed crops such as soy and canola (Sheehan et al., 1998). However, their results also showed that large-scale algae cultivation for energy production was uneconomical at that time and suggested future research into waste - stream integration (Sheehan et al., 1998). It is hoped that the economics will be ultimately improved by

**Oilgae – Home of Algal Energy**

To order a copy of the report, visit - <https://secure.clixoo.com/purchase/oilgae/wwt/report.html>

combining biodiesel feedstock production with agricultural or municipal wastewater treatment and CO<sub>2</sub> fixation.

Algae can be used to make bioethanol and biobutanol and by some estimates can produce vastly superior amounts of vegetable oil, compared to terrestrial crops grown for the same purpose. Algae can be grown to produce hydrogen. In 1939 a German researcher named Hans Gaffron, while working at the University of Chicago, observed that the algae he was studying, *Chlamydomonas reinhardtii* (a green-algae), would sometimes switch from the production of oxygen to the production of hydrogen. Algae can be grown to produce biomass, which can be burned to produce heat and electricity.

**Oilgae – Home of Algal Energy**

To order a copy of the report, visit - <https://secure.clixoo.com/purchase/oilgae/wwt/report.html>

# 2 Municipal Wastewater Treatment Using Algae

With the help of real-life case studies, this chapter will introduce the various stages and advantages of algae-based wastewater treatment methods. This chapter also evaluates the cost and economics of algae-based municipal wastewater treatment

2.1 Introduction

2.2 Composition of Municipal Wastewater

2.3 Algal Strains Grow Well in Municipal Wastewater

2.4 Algae-based Municipal Wastewater Treatment Process

2.5 Algae-based Municipal Wastewater Treatment Systems– Design and Construction

2.6 Advantages

2.7 Cost

2.8 Case Studies

2.9 Research and Updates

**Oilgae provides selected sections of this report  
free of cost, for your reading**

Oilgae – Home of Algal Energy

To order a copy of the report, visit - <https://secure.clixoo.com/purchase/oilgae/wwt/report.html>

## Free Chapter

### 2.1 Introduction

Municipal wastewater refers to wastewater that is discarded from households. Also referred to as sanitary sewage, such water contains a wide variety of dissolved and suspended impurities. It amounts to a very small fraction of the wastewater by weight. But it is large by volume and contains impurities such as organic materials and plant nutrients that tend to rot. The main organic materials are food and vegetable waste, human waste, plant nutrient, organic waste from soaps, washing powders, etc. Municipal wastewater is also very likely to contain disease-causing microbes. Thus, disposal of domestic wastewater is a significant technical problem.

Municipal wastewater treatment facilities also must be large enough to handle extra water during storms and floods otherwise overflows occur.

### 2.2 Composition of Municipal Wastewater

Domestic sewage contains 99.9% water, 0.02-0.03% suspended solids and other inorganic (30%) and organic (70%) substances. Organic components include either nitrogenous compounds like proteins and amino acids or non-nitrogenous compounds like carbohydrates and lipids. Animal sewage is high in protein and lipids and plant sewage is rich in cellulose and lignin. Lipids in the form of fatty acids which escape digestion in the digestive system account for the lipids in the faeces. Inorganic components include ammonia, chloride salts and metals. The major sources of inorganic components in municipal wastewater are illegal disposal of pesticides.

Wastewater is charged with numerous living organisms derived from faeces, some of which may be agents to diseases. It is estimated that one gram of faeces may contain about 1000 million *E.coli*, 10-100 million of faecal streptococci and 1-10 million spores of *Clostridium perfringens*, besides several other pathogens.

Municipal wastewater is a variable liquid mixture comprising material from some or all of the following sources:

- Human waste (faeces, paper, wipes and urine + other bodily fluids) also known as black water
- Washing water (personal, clothes, floors etc.) also known as grey water
- Rainfall collected on roofs, yards, hard-standing etc.
- Ground water infiltrated into sewage pipes
- Surplus manufactured liquids from domestic sources (e.g. drinks, cooking oil, pesticides, lubricating oil, paint, cleaning liquids etc.)
- General urban rainfall run-off from roads, car-parks, roofs, side-walks or pavements

**Oilgae – Home of Algal Energy**

To order a copy of the report, visit - <https://secure.clixoo.com/purchase/oilgae/wwt/report.html>

- Sea water ingress
- Direct ingress of river water
- Direct ingress of man-made liquids (illegal disposal of pesticides, used oils etc.)

The composition of each wastewater stream varies widely, but wastewater derived from a large city can be expected to contain:

- Water (>95%)
- Non pathogenic bacteria
- Pathogens - (Bacteria, viruses, prions, parasitic worms).
- Organic particles (Faeces, hair, food, paper fibres, plant material, humus etc.)
- Soluble organic material (Urea, fruit sugars, soluble proteins, drugs, pharmaceuticals etc.)
- Inorganic particles ( sand, grit, metal particles, ceramics etc)
- Soluble inorganic material (ammonia, road-salt, sea-salt, cyanide, hydrogen sulphide, thiocyanates, thiosulphates)
- Macro-solids (sanitary towels, nappies/ diapers, condoms, needles, children's toys, body parts, etc.)
- Gases (hydrogen sulphide, carbon dioxide, methane)
- Emulsions ( oils in emulsion, paints, adhesives, mayonnaise, hair colourants)
- Toxins (pesticides, poisons, herbicides )

The primary nutrients in wastewater are nitrogen and phosphorus.

Nitrogen in municipal wastewater is derived from human wastes and from waste food primarily from household garbage-disposal units. Human waste is the major source of nitrogen in wastewater.

Phosphorus in municipal wastewater may be derived from human wastes, waste food (primarily from household garbage-disposal units), and synthetic detergents. Municipal wastewaters may contain from 5 to 20 mg/l of total phosphorus, of which 1-5 mg/l is organic and the rest is inorganic. The total domestic phosphorus contribution to wastewater is about 1.6 kg per person per year (3.5 lb per capita per year). (Shun Dar Lin, C. C. Lee 2001). Detergent-based phosphorus represents between 50 and 75% of the total phosphorus in municipal wastewater.

Apart from nitrogen and phosphorus, raw sanitary wastewater also has significant populations of microorganisms. Most of these are not harmful to humans, and some of them are helpful in wastewater treatment processes. However, humans and warm-blooded animals with diseases caused by bacteria or viruses may discharge some of these harmful organisms in their body wastes (fecal wastes)

### Oilgae – Home of Algal Energy

To order a copy of the report, visit - <https://secure.clixoo.com/purchase/oilgae/wwt/report.html>

## 2.3 Algae Strains that Grow Well in Municipal Wastewater

Algae may be unicellular or multicellular organism. Algae in wastewater range in size from tiny single cells to branched forms of visible length.

Classes of algae that are commonly found in wastewater treatment plants are:

- Green (chlorophyta) - These are freshwater species, can be unicellular or multicellular.
- Motile green (euglenophyta) - These are colonial, unicellular and flagellated.
- Yellow-green (chrysophyta) - Most forms are unicellular. In this group, the most important are diatoms which have shells composed mainly of silica.
- Blue-green (cyanophyta) - These are unicellular, usually enclosed in a sheath and have no flagella. An important characteristic is their ability to use nitrogen in cell synthesis, from the atmosphere as nutrient.

Some of algae strains that can grow well in municipal wastewater are given below.

Some of algae strains that can grow well in municipal wastewater are given below:

- Chlorella
- Pithophora sp
- Scenedesmus abundans
- Sargassum muticum
- Spirulina sp
- Botryococcus braunii
- Dunaliella salina
- Ankistrodesmus sp
- Actinastrum sp
- Microactinium sp
- Pediastrum sp

- *Chlorella* - Chlorella is used for the removal of lead (II) ions from wastewater. It is also used to remove nutrients (N and P) from domestic wastewater. It is used in the treatment of diluted piggery waste and in the detoxification of cyanide from wastewater.
- *Pithophora sp* - It is used for the removal of the malachite green dye from wastewater.
- *Scenedesmus abundans* - It is used to eliminate cadmium and copper present in contaminated water and also in the process of detoxification of cyanide from wastewater.
- *Sargassum muticum* - It is used for the removal of Methylene Blue dye from wastewater.

Oilgae – Home of Algal Energy

To order a copy of the report, visit - <https://secure.clixoo.com/purchase/oilgae/wwt/report.html>

- *Spirulina sp* - It can also be used for the biosorption of heavy metals like antimony and chromium present in wastewater.
- *Botryococcus braunii* – It is used for the removal of nitrogen, phosphorus and other simple inorganic compounds from industrial wastewater, most commonly in piggery wastewater.
- *Dunaliella salina* - It is used for the removal of heavy metals like Cu, Cd, Co and Zn and also in the treatment of hypersaline wastewater.
- *Ankistrodesmus sp* – It has immense capability to absorb metals, and there is considerable potential for using them to treat wastewaters. It removes mercury, arsenic and selenium through methylation.
- *Actinastrum sp* - Removes copper from wastewater.
- *Microactinium sp* - Removal of zinc and cadmium from wastewater. The process occurs through biosorption by *Microactinium pusillum*.
- *Pediastrum sp* – Indicators of organic compounds in wastewater. The process occurs through biosorption.

#### Related Resources

- The composition of algal flora and the periodicity of algae in raw and stabilized wastewater have been investigated. 36 genera and 70 species of algae are reported.( V. P. Singh and P. N. Saxena 1968)
- Members of Cyanophyta and Euglenophyta predominate in raw wastewater, and there is little variation in the algal flora in different seasons (V. P. Singh and P. N. Saxena 1968).
- There is a marked and rapid change in the algal flora of stabilized wastewater as compared to raw wastewater. Members of Chlorococcales ultimately become dominant in stabilized wastewater.<sup>1</sup>
- A study of sewage pond microbial population in the USA and other American countries indicated a total of 125 genera. Among them the most abundant were: Chlorella, Ankistrodesmus, Scenedesmus, Euglena, Chlamydomonas, Oscillatoria, and Microactinium. However, two strands of green algae, namely Microactinium and Scenedesmus, are believed

---

<sup>1</sup><http://www.springerlink.com/content/r6h11764u78g3803/>



to make up most of the algae biomass and to be responsible for most of the nutrient uptake (Craggs 2005).

- Chlorella effectively treats wastewater and is common to oxidation pond systems (Hammouda et al. 1994).
- The number of algal species predominant in sewage are limited to a few only, such as Chlorella spp. and Oscillatoria spp. (E.W. Becker 1994)
- The green alga *Scenedesmus obliquus* readily adapted to heterotrophic growth in the dark, utilizing glucose as the sole carbon source in high rate algal ponds (Abeliovich A, Weisman D. 1978)
- Unicellular green algae such as Chlorella and Scenedesmus have been widely used in wastewater treatment because they often colonize the ponds naturally, and they have fast growth rates and high nutrient uptake capabilities per unit biomass due to their small size (Malone, 1980; Niklas, 1994; Tang, 1996).
- Biomass productivities of 23-57 mg d.m. l<sup>-1</sup> day<sup>-1</sup>, combined with rates of ammonium and phosphate removal up to 20 mg/l/day indicated that *P. bohnneri* has a good potential for wastewater treatment. (Laliberte G 1991)

## 2.4 Algae-based Municipal Wastewater Treatment Process

Municipal waste water is usually treated to get rid of undesirable substances by subjecting the organic matter to biodegradation by microorganisms such as bacteria. The biodegradation involves the degradation of organic matter to smaller molecules (CO<sub>2</sub>, NH<sub>3</sub>, PO<sub>4</sub> etc.), and requires constant supply of oxygen. The process of supplying oxygen is expensive, tedious, and requires a lot of expertise and manpower. These problems are overcome by growing microalgae in the ponds and tanks where wastewater treatment is carried out. The algae release the O<sub>2</sub> while carrying out the photosynthesis which ensures a continuous supply of oxygen for biodegradation. Algae-based municipal wastewater treatment systems are mainly used for nutrient removal (removal of nitrogen and phosphorous). The added benefit is the resulting biomass that can be used as biofuel feedstock.

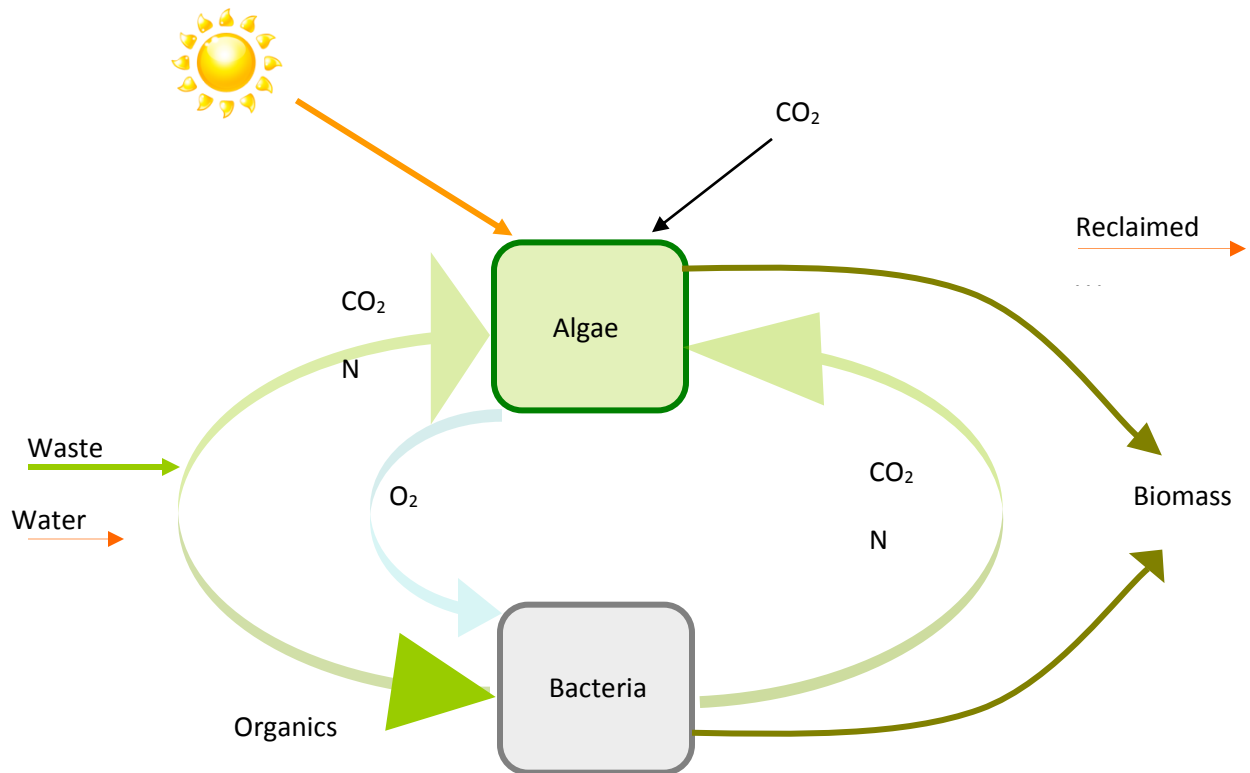
*Biodegradation of organic waste by algae and bacteria*

Nutrients, such as nitrogen and phosphorus, can be removed from wastewater in several ways. The most common way of removing nitrogen is through denitrification leading to reduction of nitrate to nitrogen gas, which is released to the atmosphere (e.g. Metcalf & Eddy et al., 2003). Phosphorus, on the other hand, is often removed by chemical precipitation using FeCl<sub>3</sub>, etc. However, both phosphorus and nitrogen can be removed by assimilation. This can be accomplished through the growth of bacteria or algae in the wastewater and then the removal of that biomass. The technique of promoting algae growth for nutrient removal was first developed by Oswald et al., (1957).

Microalgae ponds have been utilized for several decades for the treatment of municipal and other wastewaters, with the microalgae mainly providing dissolved oxygen for bacterial decomposition of the organic wastes. Algae and bacteria exist in a classic symbiotic relationship. Bacteria metabolize organic waste for growth and energy, producing new bacterial biomass and releasing carbon-di-oxide and inorganic nutrients. Algae then utilize the CO<sub>2</sub> through photosynthesis assimilating the nutrients into algal biomass and releasing O<sub>2</sub> concentration, in turn supports the aerobic bacterial activity. Use of *Chlorella* seems to be one of the feasible methods to reduce the amount of nitrogen and phosphorus entering the nearby coastal water, thus preventing the eutrophication problem which results in depletion of oxygen in water followed by fish death.

### Oilgae – Home of Algal Energy

To order a copy of the report, visit - <https://secure.clixoo.com/purchase/oilgae/wwt/report.html>

The below schematic for an advanced municipal wastewater treatment process uses a multi-stage pond system for complete organic waste degradation and nutrient removal. The initial wastewater treatment ponds are shown, followed by a smaller intermediate "green algae" pond for N depletion, and a final pond for cultivating N-fixing blue-green algae and removing residual phosphates. CO<sub>2</sub> supplementation would be required in the last two ponds, and could increase productivity in the initial pond. (Source: Benemann et al. 1978)

**Oilgae – Home of Algal Energy**

To order a copy of the report, visit - <https://secure.clixoo.com/purchase/oilgae/wwt/report.html>

Process Schematic for Municipal Wastewater Treatment with Microalgae

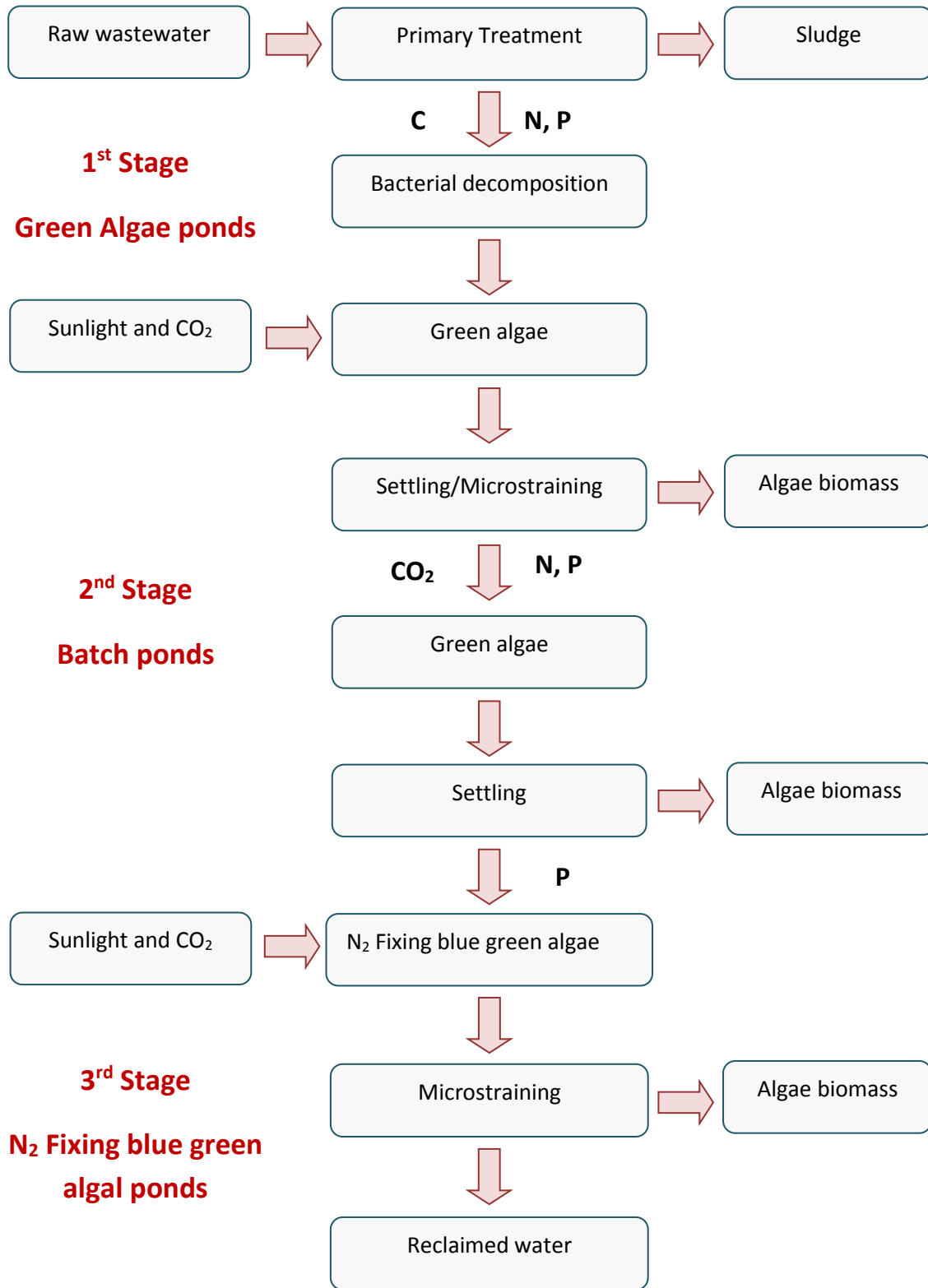

Oilgae – Home of Algal Energy

To order a copy of the report, visit - <https://secure.clixoo.com/purchase/oilgae/wwt/report.html>

Processes involved in the removal of nutrient are precipitation, stripping and uptake by algal biomass (De la Noue & De Pauw, 1988). As a general principle, algae require a supply of inorganic nutrients, sufficient light, and favorable temperatures to grow (Fogg, 1975; Bold and Wynne, 1978). Inorganic nutrients that may cause eutrophication can be either available in the water or being biologically decomposed from organic material.

#### 2.4.1 Nitrogen Removal by Algae

Biological removal of nitrogen from wastewater involves three basic steps:

1. Synthesis – incorporation of nitrogen into microbial biomass as a result of cell growth
2. Nitrification – conversion of organic nitrogen and ammonia into nitrate by nitrifying microorganisms
3. Denitrification – conversion of nitrates into nitrogen gas by denitrifying organisms

Algal growth rate is unaffected by inorganic nitrogen source ( $\text{NH}_4\text{-N}$ ,  $\text{NO}_3\text{-N}$ ,  $\text{NO}_2\text{-N}$ ) (South and Whittick, 1987). However, nitrate and nitrite must be reduced to ammoniacal-N before assimilation, (Oh-Hama and Miyachi 1988) as only free ammonia ( $\text{NH}_3$ ) can be assimilated by the algae (Abeliovich and Azov, 1976; Chevalier and de la Noue, 1985)

The reason that algae assimilate ammoniacal-N and other reduced forms of nitrogen (eg. urea) in preference to oxidized forms of nitrogen (nitrite and nitrate) is due to the greater energy requirement for nitrate reduction (Oswald et al., 1953) In addition, the presence of ammoniacal-N prevents nitrate assimilation by inhibiting the production of nitrate reductase (Thompson et al., 1989)

#### *Ammonia Removal Comparison for Algae Treatment Systems*

Algae species	% $\text{NH}_3\text{-N}$ removal	Media	Study
Scenedemus obliques	80-100	Autoclaved municipal wastewater	Martinez (2000)
Arthrouspira plantensis	99	Anaerobic treated dairy wastewater	Lincoln (1996)
Mixed culture	99	Municipal wastewater	Green (1995)
Mixed culture	96	Anaerobic treated dairy wastewater	Ian Charles (2007)

Cromar et al., (1996) found a relationship between algal biomass and the removal of nitrogen. This relationship demonstrated that there was an optimum level of algal biomass, between 2 and 5 mg/l above which the efficiency of nitrogen removal declined rapidly. The finding that maximum nutrient removal was achieved at relatively low concentrations of algal biomass indicates that there exists an optimum algae density in the pond. Higher algal densities will

**Oilgae – Home of Algal Energy**

To order a copy of the report, visit - <https://secure.clixoo.com/purchase/oilgae/wwt/report.html>

achieve a lower productivity and nutrient uptake rate due to increased light attenuation, which causes self-shading (Hartig et al., 1988).

#### 2.4.2. Phosphorous Removal by Algae

Phosphate removal is currently achieved largely by chemical precipitation, which is expensive and causes an increase of sludge volume by up to 40%. An alternative is the biological phosphate removal (BPR). In the biological removal of phosphorous, the phosphorous in the influent wastewater is incorporated into cell biomass, which is subsequently removed from the process as a result of sludge wasting.

Phosphate is the only form assimilated by algae but at low phosphate concentrations. Organic phosphorus may be hydrolyzed by phosphatase enzymes produced at cell surface (Fogg 1975). Once assimilated, Algae convert phosphate into polyphosphates which serve as reservoirs of high energy phosphate for ATP synthesis.

*Rate of Nitrogen and Phosphate Removal by Algae*

Inlet concentration of (mg/l)				HRT (day)	Removal rate (%)	Reference
TAN	NO <sub>3</sub> <sup>-</sup> -N	NO <sub>2</sub> <sup>-</sup> -N	PO <sub>4</sub> <sup>-</sup> -N			
			7.0 – 15.0	2 - 6	94 - 97	Oswald(1988)
			18.4 - 20.6	2 - 3	14 – 15	Gal (2003)
0.92 – 1.47				2 – 3	78 - 83	
	170.3-187.4			2 - 3	0	
		2.43 -3.30		2 - 3	82.0	
80.5 – 90.3				4	80 – 90	Borowitzka,(1998)
	1.6 – 18.8			4	90.8	Canizares et al,(1994)

#### 2.4.3 Pathogen Removal by Algae

Many different mechanisms play a role in disinfection in high rate ponds. These include predation, sunlight, temperature, dissolved oxygen, pH, sedimentation and starvation (Fallowfield et al., 1996). Algal photosynthesis causes an increase in the pH due to the simultaneous removal of CO<sub>2</sub> and H<sup>+</sup> ions (Fallowfield et al., 1996) and the uptake of bicarbonate when the algae are carbon limited (Craggs et al., 1997). According to Rose et al. (2002a) a pH of 9.2 for 24 hours will provide a 100% kill of E. coli and most pathogenic bacteria and viruses. Pahad and Rao (1962) also found that E. coli could not grow in wastewater with a pH higher than 9.2.

Oilgae – Home of Algal Energy

To order a copy of the report, visit - <https://secure.clixoo.com/purchase/oilgae/wwt/report.html>

*Pathogen Removal Performance of the High Rate Algal Pond Unit Operation, Configured In Series*

Treatment Units	E.coli Concentration (cfu.100 ml <sup>-1</sup> )
Primary Facultative Pond (raw effluent)	5.8×10 <sup>5</sup>
HRAP 1	6.7×10 <sup>3</sup>
HRAP 2	4.8

Source: *Tertiary Treatment in Integrated Algal Ponding Systems* by Charles Digby Wells, Rhodes University (January 2005)

## 2.5 Algae-based Treatment Systems – Design and Construction

To construct algae based wastewater treatment system it is essential to consider both wastewater treatment as well as algal cultivation. Cell retention time, nutrient addition rate, water depth, and degree of mixing are the common parameters consider for growth of algae. In addition to these parameters BOD reduction, TDS reduction, pH, Nitrogen removal rate and Phosphorus removal rate are commonly considered for wastewater treatment. Hence the system should be designed accordingly to allow the growth of algae as well as wastewater treatment.

Many wastewater treatment plants (WwTP) of all kinds in developing countries do not function properly. Parr and Horan (1994) found that there are three principal reasons for WwTP failure: a lack of technical knowledge; failure to consider all relevant local factors at the pre-design stage; and inappropriate discharge standards. There is a lot of technical expertise required to achieve algae cultivation in wastewater treatment facility.

Two types of wastewater treatment systems are currently available for algae based treatment which can be incorporated in secondary treatment stages.

1. Waste Stabilization Pond Systems ( WSPs)
2. High Rate Algal Ponds( HRAP)

### 2.5.1 Waste Stabilization Pond Systems

#### *Role of Algae in WSPs*

Wastewater treatment in Waste Stabilization Ponds (WSPs) is "green treatment" achieved by the mutualistic growth of microalgae and heterotrophic bacteria. The algae produce oxygen from water as a by-product of photosynthesis. This oxygen is used by the bacteria as they aerobically bio-oxidize the organic compounds in the wastewater. An end-product of this bio-oxidation is carbon dioxide, which is fixed into cell carbon by the algae during photosynthesis.

Waste Stabilization Ponds (WSPs) are large, shallow basins in which raw wastewater are treated entirely by natural processes involving both algae and bacteria. They are used for wastewater treatment in temperate and tropical climates, and represent one of the most cost-effective, reliable and easily-operated methods for treating municipal and industrial wastewater. Waste stabilization ponds are very effective in the removal of pathogens such as faecal coliform bacteria. Sunlight energy is the only requirement for its operation. Further, it requires minimum supervision for daily operation, with simple cleaning of the outlets and inlet works, being the only tasks. The temperature and duration of sunlight in tropical countries offer an excellent opportunity for high efficiency and satisfactory performance for this type of water-cleaning system. They are well-suited for low-income tropical countries where conventional wastewater treatment cannot be achieved due to the lack of a reliable energy source. Further, the advantage of these systems, in terms of removal of pathogens, is one of the most important reasons for its use.

#### *Types of Waste Stabilization Ponds and Their Specific Uses*

WSP systems comprise of anaerobic and aerobic ponds for the removal of Biochemical Oxygen Demand (BOD), and maturation ponds for pathogen removal. The aerobic ponds include:

**Primary facultative ponds:** It receives raw wastewater. The BOD is primarily removed by the oxidation of organic matter by aerobic bacteria.

**Secondary facultative ponds:** These ponds receive the wastewater from the primary facultative ponds or an earlier treatment process such as anaerobic digestion. The remaining BOD is oxidized by heterotrophic bacteria. The oxygen required for oxidation of BOD is obtained from photosynthetic activity of the micro-algae.

**Maturation ponds:** It receives the effluent from the facultative ponds. Their primary function is to remove excreted pathogens.

**Oilgae – Home of Algal Energy**

To order a copy of the report, visit - <https://secure.clixoo.com/purchase/oilgae/wwt/report.html>



WSP systems comprise a single string of anaerobic, aerobic and maturation ponds in series, or several such series in parallel. In essence, anaerobic and aerobic ponds are designed for the removal of Biochemical Oxygen Demand (BOD), and maturation ponds for pathogen removal, although some BOD removal also occurs in maturation ponds and some pathogen removal in anaerobic and facultative ponds (Mara, 1987). In most cases, only anaerobic and aerobic ponds will be needed for BOD removal when the effluent is to be used for restricted crop irrigation and fish pond fertilization, as well as when weak wastewater is to be treated prior to its discharge to surface waters. Maturation ponds are only required when the effluent is to be used for unrestricted irrigation, thereby having to comply with the WHO guideline of  $\leq 1000$  faecal coliform bacteria/100 ml. The WSP does not require mechanical mixing, needing only sunlight to supply most of its oxygenation. Its performance may be measured in terms of its removal of BOD and faecal coliform bacteria.

### *Processes in Waste Stabilization Ponds*

#### *Anaerobic Treatment:*

*Anaerobic ponds* - Anaerobic ponds are commonly 2 – 5 m deep and receive wastewater with high organic loads (i.e., usually greater than 100 g BOD/m<sup>3</sup>.day, equivalent to more than 3000 kg/ha.day for a depth of 3 m). The ponds normally do not contain dissolved oxygen or algae. In anaerobic ponds, BOD removal is achieved by sedimentation of solids, and subsequent anaerobic digestion in the resulting sludge. The process of anaerobic digestion is more intense at temperatures above 15<sup>o</sup> C. The anaerobic bacteria are usually sensitive to pH <6.2. Thus, acidic wastewater must be neutralized prior to its treatment in anaerobic ponds. A properly-designed anaerobic pond will achieve about a 40% removal of BOD at 100<sup>o</sup> C, and more than 60% at 200<sup>o</sup> C. A shorter retention time of 1.0 - 1.5 days is commonly used.

#### *Aerobic Treatment*

Algae play a major role in this phase of treatment.

*Facultative Ponds* - Facultative ponds (1-2 m deep) are of two types: Primary facultative ponds that receive raw wastewater, and secondary facultative ponds that receive particle-free wastewater (usually from anaerobic ponds, septic tanks, primary facultative ponds, and shallow sewerage systems). The process of oxidation of organic matter by aerobic bacteria is usually dominant in these facultative ponds.

It is estimated that about 30% of the influent BOD leaves the primary facultative pond in the form of methane (Marais 1970). A high proportion of the BOD that does not leave the pond as methane ends up in algae. This process requires more time, more land area, and possibly 2 -3 weeks water retention time, rather than 2 -3 days in the anaerobic pond. In the secondary facultative pond (and the upper layers of primary facultative ponds), wastewater BOD is converted into algal biomass, and has implications for effluent quality requirements. About 70

Oilgae – Home of Algal Energy

To order a copy of the report, visit - <https://secure.clixoo.com/purchase/oilgae/wwt/report.html>

– 90% of the BOD of the final effluent from a series of well-designed WSPs is related to the algae they contain.

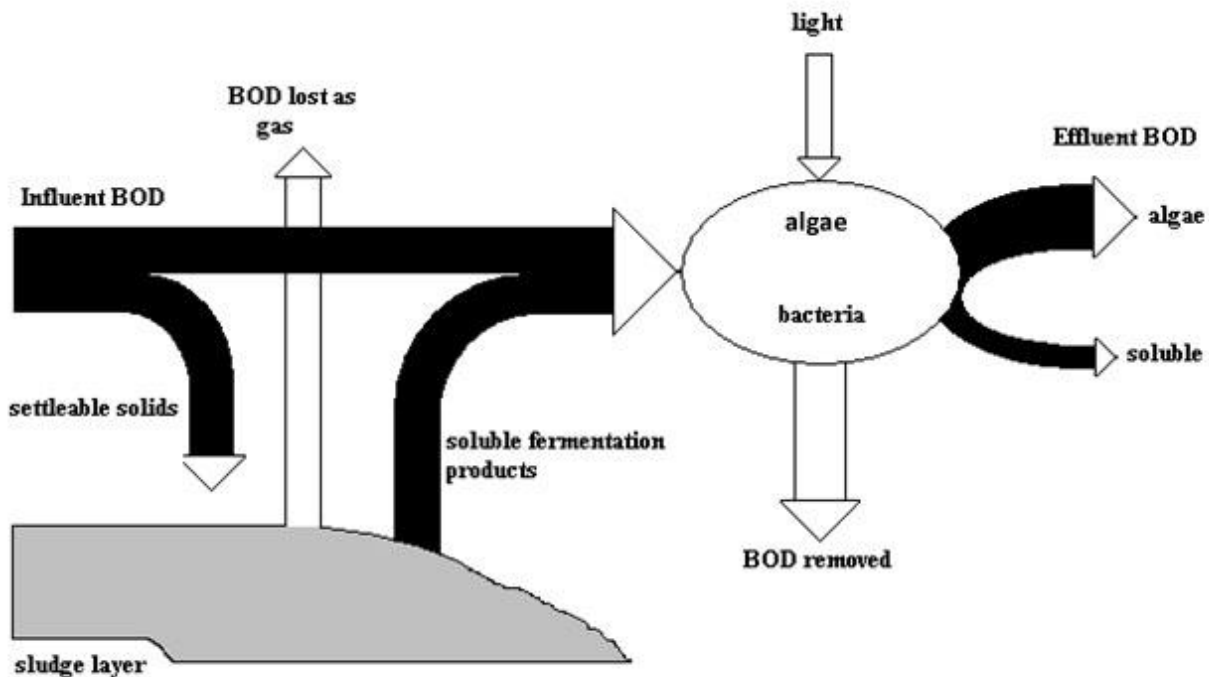

In secondary facultative ponds that receive particle-free wastewater (anaerobic effluent), the remaining non-settleable BOD is oxidised by heterotrophic bacteria (*Pseudomonas*, *Flavobacterium*, *Archromobacter* and *Alcaligenes* spp). The oxygen required for oxidation of BOD is obtained from photosynthetic activity of the micro-algae that grow naturally and profusely in facultative ponds.

Facultative ponds are designed for BOD removal on the basis of a relatively low surface loading (100 – 400 kg BOD/ha.day); in order to allow for the development of a healthy algal population, since the oxygen for BOD removal by the pond bacteria is generated primarily via algal photosynthesis. The facultative pond relies on naturally-growing algae. The facultative ponds are usually dark-green in colour because of the algae they contain. Motile algae (*Chlamydomonas* and *Euglena*) tend to predominate the turbid water in facultative ponds, compared to non-motile algae (*Chlorella*).

The algal concentration in the pond depends on nutrient loading, temperature and sunlight, but is usually in the range of 500 - 2000 µg chlorophyll-*a*/liter (Mara, 1987). Because of the photosynthetic activities of pond algae, there is a diurnal variation in the dissolved oxygen concentration. The dissolved oxygen concentration in the water gradually rises after sunrise, in response to photosynthetic activity, to a maximum level in the mid-afternoon, after which it falls to a minimum during the night, when photosynthesis ceases and respiratory activities consume oxygen. At peak algal activity, carbonate and bicarbonate ions react to provide more

**Oilgae – Home of Algal Energy**

To order a copy of the report, visit - <https://secure.clixoo.com/purchase/oilgae/wwt/report.html>

carbon dioxide for the algae, leaving an excess of hydroxyl ions. As a result, the pH of the water can rise to above 9, which can kill faecal coliform. Good water mixing, which is usually facilitated by wind within the upper water layer, ensures a uniform distribution of BOD, dissolved oxygen, bacteria and algae, thereby leading to a better degree of waste stabilization.

### *Maturation Ponds*

The maturation ponds, usually 1-1.5 m deep, receive the effluent from the facultative ponds. Their primary function is to remove excreted pathogens. Although maturation ponds achieve only a small degree of BOD removal, their contribution to nutrient removal can be significant. Maturation ponds usually show less vertical biological and physicochemical stratification, and are well-oxygenated throughout the day. The algal population in maturation ponds is much more diverse than that of the facultative ponds, with non-motile genera tending to be more common. The algal diversity generally increases from pond to pond along the series (Mara, 1989). Although faecal bacteria are partially removed in the facultative ponds, the size and numbers of the maturation ponds especially determine the numbers of faecal bacteria in the final effluent. There is some removal of solids-associated bacteria in anaerobic ponds, principally by sedimentation.<sup>2</sup>

## **2.5.2 High Rate Algal Pond Systems**

### **Role of Algae in HRAP**

The HRAP is a combination of intensified oxidation ponds and an algal reactor. HRAP are shallow, paddlewheel-mixed open raceway ponds and provide far more efficient wastewater treatment. Than conventional oxidation ponds, this is primarily as a result of intense algal photosynthesis providing saturated oxygen to drive aerobic treatment and assimilation of wastewater nutrients into algal biomass.

The high-rate algal pond (HRAP) is a low-cost wastewater treatment system designed to achieve two goals: secondary wastewater treatment and algal biomass production. The HRAP is a combination of intensified oxidation ponds and an algal reactor. Algae supply the oxygen demand for bacterial degradation of organic matter, and bacteria excrete mineral compounds that provide the algae with nutrition. HRAPs have proved effective in removing organic matter and in reducing bacterial contamination and the number of nematode eggs.

---

<sup>2</sup>[http://www.unep.or.jp/ietc/Publications/Water\\_Sanitation/ponds\\_and\\_wetlands/Design\\_Manual.pdf](http://www.unep.or.jp/ietc/Publications/Water_Sanitation/ponds_and_wetlands/Design_Manual.pdf)

These ponds can be integrated into the existing wastewater treatment systems for aerobic treatment of waste.

High-rate algal ponds have been studied for many years as a means of wastewater treatment and resource recovery in the form of protein-rich microalgal biomass. A wide variety of algal species is present in the high-rate ponds. The high-rate algal ponds are, potentially, an effective disinfection mechanism within the requirements of sustainability. In addition to disinfection, nutrient removal mechanisms are also active in the HRAP, specifically those involved in the removal of phosphate.

HRAP are also much more cost-effective than energy intensive mechanical wastewater treatment systems providing similar wastewater treatment. High rate algal ponds are efficient systems to treat domestic and industrial wastewater.

In HRAPs algal biomass productivity levels vary quite widely during the year. High levels, of up to 60 g/m<sup>2</sup>/day, have been achieved during periods of sunny weather, whereas during the rainy season towards the end of the year, the productivity level dropped below 10 g/m<sup>2</sup>/day. On the average, the high-rate algal ponds in Singapore produced about 23 g/m<sup>2</sup>/day. This represents a productivity level much higher than some reported from California and is equivalent to those reported in Thailand (Feb 1988).

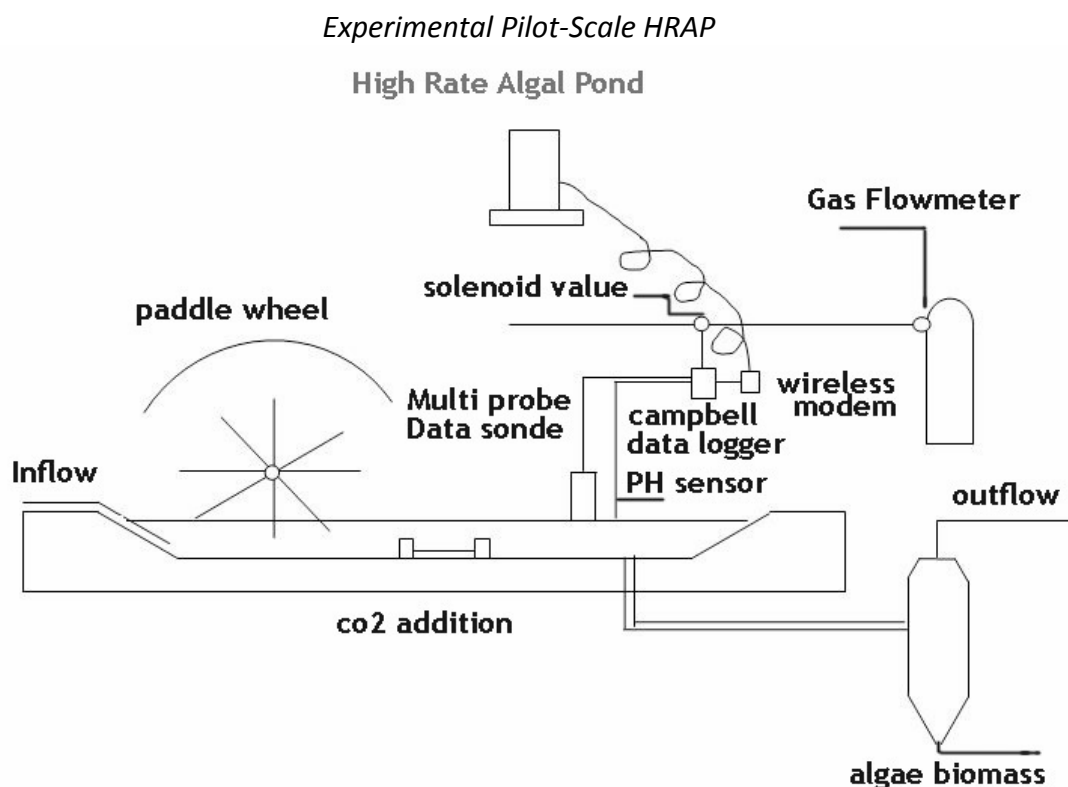

Source: <http://www.acquacon.com.br/ponds2009/palestras/27-04/room2/07pap207parkcraaqs.pdf>

**Oilgae – Home of Algal Energy**

To order a copy of the report, visit - <https://secure.clixoo.com/purchase/oilgae/wwt/report.html>

Types of algae culture in a High Rate Algal Pond varies significantly. Instability of the algal cultures and fluctuations in algal flora are often observed owing to a number of factors. Some of these factors, for example, operational conditions and invasion by natural grazing organisms such as rotifers and *Moina*, can be controlled to a certain extent, while the effects caused by other factors, e.g. climatic and physico-chemical changes in the pond due to the organic content in the waste from the pig farm, cannot be easily controlled.

Species like *Oscillatoria*, *Micractinium*, *Spirulina* and *Scenedesmus* are desirable to grow in high rate algal ponds for harvesting purposes because of their larger size as compared with the single cellular forms such as *Chlorella* and *Oocystis*, which are difficult to harvest.

#### *Conventional Facultative Ponds vs. High Rate Algal Ponds*

The major differences between conventional facultative ponds and high rate algal ponds are given below.

Parameters	Conventional Facultative Ponds	High Rate Ponds
Mixing	Little mechanical mixing	Paddle wheel mixing
Residence time	20 – 100 days	4 – 10 days

#### *Process for High Rate Algal Ponds (HRAP)*

HRAP are shallow, paddlewheel-mixed open raceway ponds are far more efficient wastewater treatment than conventional oxidation ponds primarily as a result of intense algal photosynthesis providing saturated oxygen to drive aerobic treatment and assimilation of wastewater nutrients into algal biomass. The shallow pond depth and continuous mixing of HRAP assist with disinfection of the wastewater by sunlight. High rate algal ponds are efficient systems to treat wastewater. For instance, a 1000-m<sup>2</sup> HRAP is capable of treating 50 m<sup>3</sup> of wastewater daily.

The figure below explains about the HRAP developed by Solray Energy, a New Zealand company, wherein they have developed a Super Critical Water Reactor (SCWR) technology which has the capability to convert algae and other biomass sources into crude bio-oil. This technology also has great potential to degrade toxic organic compounds to harmless residues.

A Schematic Diagram of a HRAP System

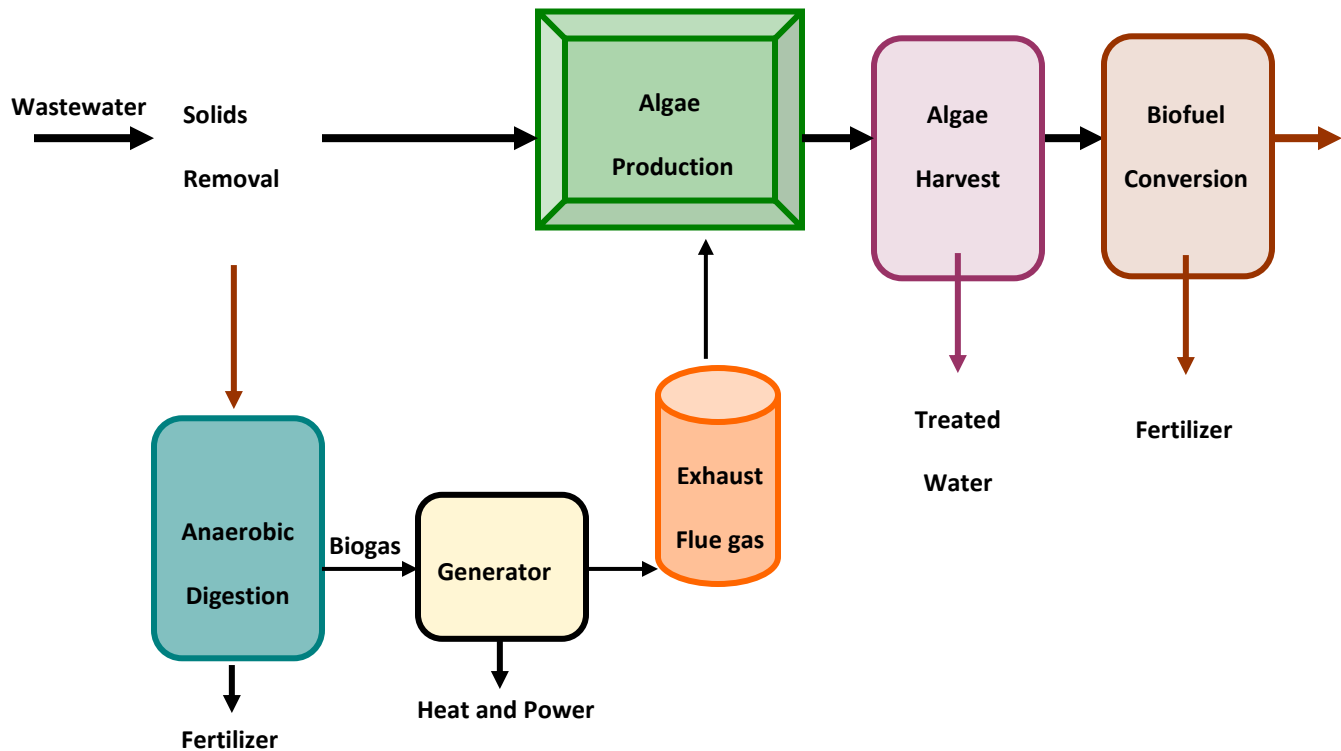

Source: <http://www.niwa.co.nz/our-science/freshwater/research-projects/all/biofuel-from-wastewater-algae#null>

The typical HRAPs consist of a shallow 0.2 - 0.6 cm deep meandering open channel, in which the effluent is propelled by a paddlewheel (6 to 8 rpm) to prevent settling and compensate for head losses, and a solid removal device (Oswald, 1988). To be effective most HRAPs were designed with shallow depth (30 - 50 cm), short retention time (2 – 6 days), mechanical mixing (energy consuming), and aerobic environment (organic oxidation). Most ponds are operated at an average velocity from 10 - 30 cm/second to avoid deposition of algal cells (Dodd, 1986). The pH values maintained as high as 8.5 to 9 with the organic loading rate of 80kg COD T per hectare per day.

Oilgae – Home of Algal Energy

To order a copy of the report, visit - <https://secure.clixoo.com/purchase/oilgae/wwt/report.html>

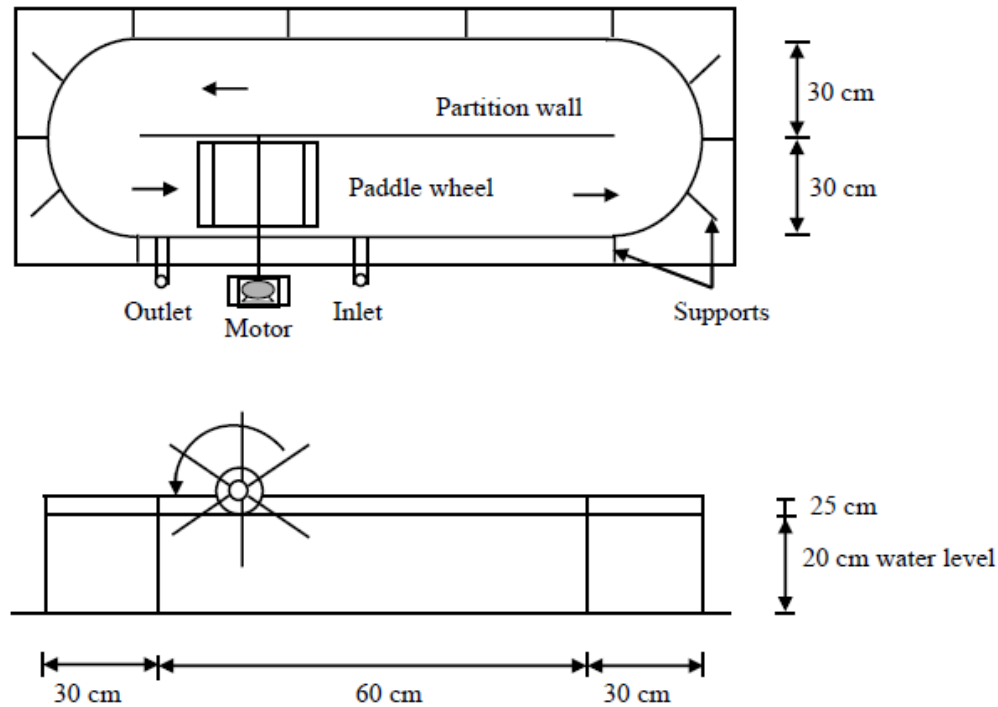

### *CO<sub>2</sub> Enhanced HRAP*

Carbon-di-oxide is an essential component of photosynthesis. Apparently, free carbon dioxide concentration in the pond is the major determinant of carbon limiting algal photosynthesis. High concentrations of free CO<sub>2</sub> are provided through bacterial respiration. At high photosynthetic activities and low organic loadings, free CO<sub>2</sub> concentrations are low which in turn limits algal growth. Hence carbon dioxide should be added into the HRAP to meet the requirement. CO<sub>2</sub> is sparged mechanically in these ponds.

Generally, the wastewater consists of Carbon, Nitrogen and Phosphorus in the ratio of 20:8:1. The ratio of Carbon, Nitrogen and Phosphorus required by algae is 50:8:1. So, the additionally required 30% of carbon is supplied by sparging CO<sub>2</sub> in these ponds.

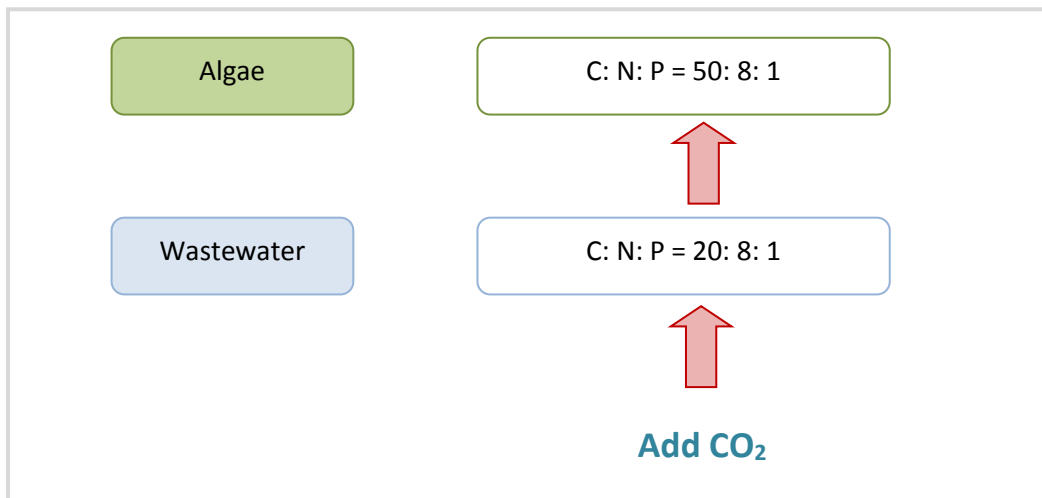
*CO<sub>2</sub> Balance in Wastewater Treatment Systems*

CO<sub>2</sub>-enhanced high rate ponds have several advantages over the normal HRAPs:

- Improved and accelerated treatment
- Energy used in wastewater treatment decreases
- Biomass fuel provides greenhouse gas abatement
- The residual algae biomass after oil extraction can be used as fertilizer.

### **2.5.3 High Rate Algal Pond and Waste Stabilization Pond System – A Comparison**

WSPs and HRAPs have been operated independently in various parts of the world; however, the performance of these systems has rarely been compared in the same location. WSPs are relatively shallow and unmixed and as a consequence experience thermal stratification, with temperature variations of up to 12°C between the lagoon surface and bottom recorded (Sweeney et al, 2005). This results in dissolved oxygen stratification with aerobic and anaerobic conditions occurring at the surface and bottom of the lagoon respectively. These variations in conditions throughout the depth influence the reaction rates of key treatment processes such as nutrient and BOD removal ( Sweeney et al, 2007 ) and pathogen die-off (Sweeney et al, 2004). These systems may also suffer hydraulic short-circuiting, producing retention times shorter than those designed, which may result in insufficient treatment of the effluent (Sweeney et al, 2003).

High rate algal ponds (HRAPs) are shallow, mixed systems consisting of a series of interconnecting baffled channels. The process of gentle mixing, using a paddlewheel, avoids thermal stratification and produces more a homogenous chemical environment throughout the pond. These conditions result in high rates of algal photosynthesis and consequently high

**Oilgae – Home of Algal Energy**

To order a copy of the report, visit - <https://secure.clixoo.com/purchase/oilgae/wwt/report.html>



**Thanks for reading the free chapter from Oilgae's  
Guide to Waste Water Treatment!**

**Oilgae – Home of Algal Energy**

To order a copy of the report, visit - <https://secure.clixoo.com/purchase/oilgae/wwt/report.html>

## Other Sample Content in the Section

### Cost of Municipal Wastewater Treatment Using Algae

Key issues discussed in this section for cost-effective wastewater phycoremediation are:

- Optimal Treatment Systems & Processes
- Cost-effective Harvesting Systems
- Exploiting the Value of End-products and Processes

#### *Optimal Treatment Systems & Processes*

Wastewater treatment using algae are implemented either using simple oxidation ponds or with high rate algal ponds. In a few cases, especially where high productivity of algal biomass is desired, companies are exploring the possibility of using closed systems such as photobioreactors as well.

The following are our observations in the context of optimal systems and processes for wastewater phycoremediation:

- Based on reviews and researches done so far regarding economics of algae-based wastewater treatment, it can be concluded that photobioreactors are not economic for such treatments in the short and medium term (even if it is intended to derive significant economic benefits from the sale of algal biomass). Such a closed and controlled environment for cultivation will become viable only after the costs of such systems come down dramatically.

More such critical perspectives and insights are provided for all the three issues mentioned above, viz. **Optimal Treatment Systems & Processes**, **Cost-effective Harvesting Systems** and **Exploiting the Value of End-products and Processes**.

### Sample Content: Research & Updates

- In May 2009, the National Institute of Water and Atmospheric Research based in New Zealand set out to demonstrate the commercial feasibility of bio-oil production from algae cultivated in waste-water treatment facilities. Specifically, they utilized High Rate Algal Ponds (HRAP) to study the efficiency of conversion of algae biomass to bio-oil. As a result of their studies, 5 hectares of oxidation ponds at Christchurch Wastewater Treatment Plant were converted into the world's first large scale wastewater treatment High Rate Algal Ponds. Now, four 1.25ha of HRAP treat 2000m<sup>3</sup> per day of primary

**Oilgae – Home of Algal Energy**

To order a copy of the report, visit - <https://secure.clixoo.com/purchase/oilgae/wwt/report.html>

effluent from the plant. Moreover, they use 500m<sup>3</sup> of CO<sub>2</sub> produced by the electrical generators of the treatment plant. The algae is harvested by gravity settling for conversion into bio-crude oil by another collaborator, Solray Energy. The project was jointly commissioned by the Christchurch City Council, the National Institute of Water and Atmosphere Research and Solray Energy.

- HY-TEK BIO, LLC and University of Maryland's Center for Environmental Sciences (*UMCES*) jointly obtained a \$100,000 grant from the state of Maryland under its Maryland Industrial Partnerships (MIPS) Program. In late 2011, a demonstration scale project was built at Baltimore's Back River water treatment plant. Since then, flue-gas output and greenhouse gas emissions from a nearby 3MW power-plant have been used to cultivate HTB1 algae that can thrive in 100% CO<sub>2</sub>.
- Zhiyou Wen and Martin Gross, from the Center for Crops Utilization Research in the Iowa State University developed a Revolving Algal Biofilm treatment system. The system consists of vertical conveyer belts revolving in a continual loop thereby cycling through wastewater and air more efficiently than other systems of treatment. The Metropolitan Water Reclamation District of Greater Chicago, Illinois have extended their period of study due to promising results. The algae produced in this process is being converted into fertilizers and sold by Gross-Wen Technologies, a company founded by Zhiyou Wen and Martin Gross in 2013.

**Oilgae – Home of Algal Energy**

To order a copy of the report, visit - <https://secure.clixoo.com/purchase/oilgae/wwt/report.html>

# 3 Industrial Effluent Treatment Using Algae

This chapter provides details of how an algae-based system can be used to treat industrial wastewater. This chapter describes in detail the algae-based industrial wastewater treatment systems being used by thirteen different types of industries. This chapter also gives the reader insights and case studies on the role of algae in various industrial wastewater treatments. It also provides comparative cost analyses of various algae based treatment systems implemented in different industries.

## 3.1 Introduction

## 3.2 Composition of Major Industrial Effluents

## 3.3 Algal Strains Used in Various Industrial Effluent Treatments

## 3.4 Algae Based Effluent Treatment Plant for Industrial Wastewater

## 3.5 Algae Based Industrial Wastewater Treatment – Design and Construction

## 3.6 Industry Specific Algae Based Waste Treatment and Effluent Treatment

## 3.7 Advantages of Industrial Effluent Treatment Using Algae

## 3.8 Cost

## 3.9 Case Studies

## 3.10 Research and Experiments

### Sample Content:

### 3.2 Composition of Major Industrial Effluents

The compositions as well as properties of industrial wastewaters differ considerably from domestic waste. The following table gives a comparison between the typical range of BOD and suspended solids (S.S.) load for industrial and municipal domestic wastewater.

*Typical range of BOD and S.S. load for industrial and municipal wastewater*

Origin of waste	Biochemical oxygen demand (BOD) kg/ton product	Total Suspended solids (TSS) kg/ton product
Domestic sewage	0.025 (kg/day/person)	0.022 (kg/day/person)
Dairy industry	5.3	2.2
Yeast industry	125	18.7

**Oilgae – Home of Algal Energy**

To order a copy of the report, visit - <https://secure.clixoo.com/purchase/oilgae/wwt/report.html>

Starch & glucose industry	13.4	9.7
Fruits & vegetable canning industry	12.5	4.3
Textile industry	30 - 314	55 - 196
Pulp & paper industry	4 - 130	11.5 - 26
Beverage industry	2.5 - 220	1.3 - 257
Tannery industry	48 - 86	85 - 155

Source: *Industrial Wastewater Treatment Plants Self-monitoring Manual, Chapter 2, 2002*

### Sample Content:

## 3.6 Industry Specific Algae based Waste Treatment and Effluent Treatment

This section provides extensive details on current wastewater treatment practices and the role algae plays or has the potential to play, for the following industries:

1. Poultry
2. Dairy
3. Aquaculture
4. Textiles
5. Pulp and Paper
6. Distillery & Breweries
7. Leather
8. Foods
9. Petrochemicals
10. Pharmaceuticals
11. Chemicals
12. Mining
13. Metalworking

For each of the industries mentioned, we provide details on the following headings:

- Details of the industry's wastewater characteristics
- Current treatment practices
- Algae based wastewater treatment process
- New and emerging technologies for this industry's wastewater treatment

Oilgae – Home of Algal Energy

To order a copy of the report, visit - <https://secure.clixoo.com/purchase/oilgae/wwt/report.html>

**Oilgae – Home of Algal Energy**

To order a copy of the report, visit - <https://secure.clixoo.com/purchase/oilgae/wwt/report.html>

## Poultry Industry

<b>Industry</b>	Poultry
<b>Product</b>	Poultry muscle (chicken, turkey, duck, ratite, etc.) into meat
<b>Effluent Description</b>	Fats, proteins and carbohydrates from meat, fat, blood, skin and feathers and also grit and other inorganic matter, high levels of nitrogen, phosphorus, and chlorine, pathogens like salmonella and campylobacter.
<b>Effluent Treatment Objectives</b>	Reduce sludge. Remove N, P and to neutralize odors and to remove pathogens.
<b>Current Treatment Process</b>	Separation and sedimentation of floatable solids, anaerobic and aerobic treatment, biological nutrient removal, chlorination and usage of filters.
<b>Algal treatment process</b>	Nutrient assimilation using High Rate Algal Ponds (HRAP)

### Sample Content: Algae-based Wastewater Treatment Technology – Poultry Industry

*Process of Algae Wastewater Treatment for Poultry Industry*

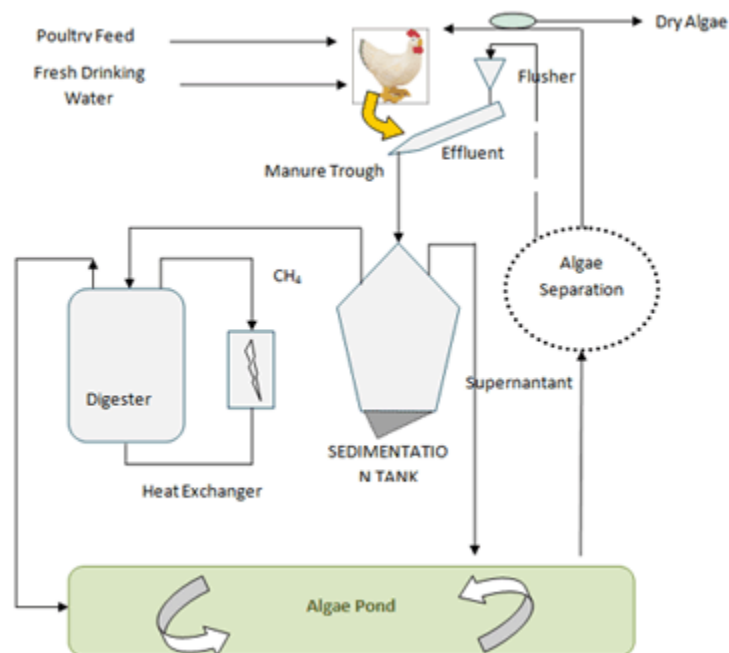

Source:FAO

**Oilgae – Home of Algal Energy**

To order a copy of the report, visit - <https://secure.clixoo.com/purchase/oilgae/wwt/report.html>

## Sample Content: Current Treatment Process Wastewater Treatment - Paper and Pulp Industry

*Current Wastewater Treatment Process in Paper Industry*

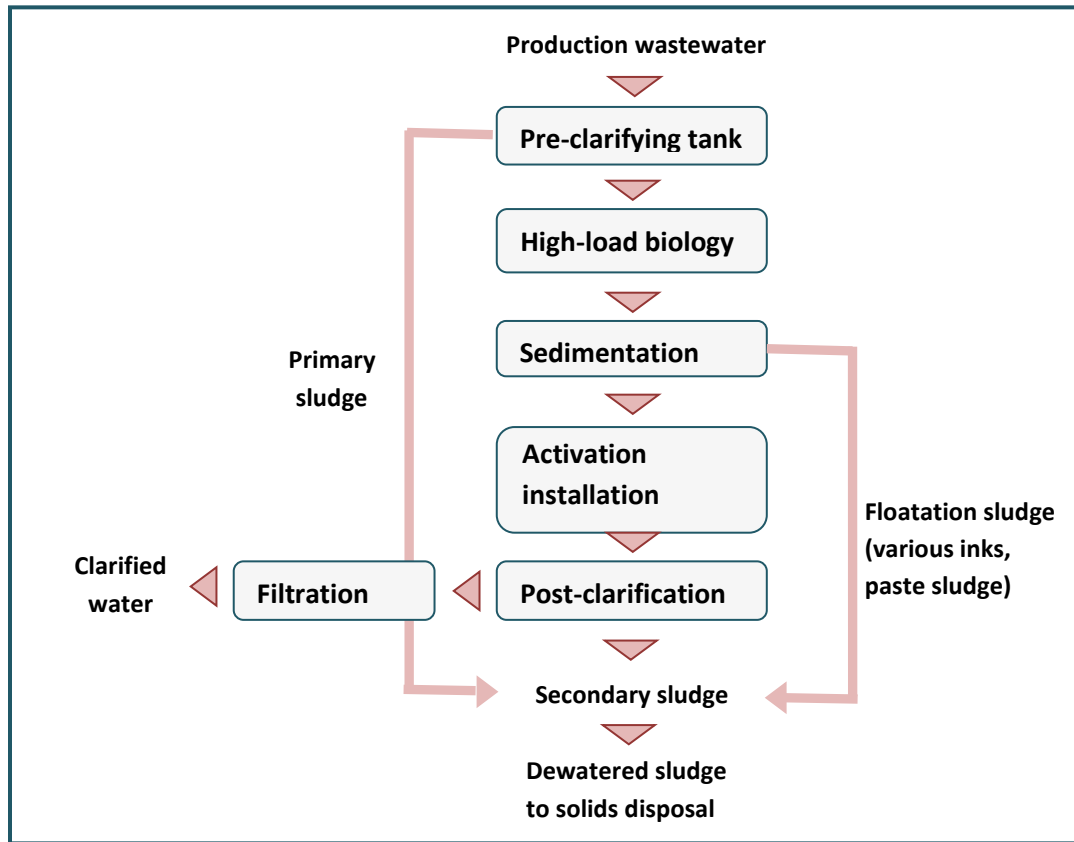

## Sample Content: Dairy Industry

A research project on the use of Algae Turf Scrubber (ATS) for dairy wastewater treatment was conducted from 2003 to 2006 by Walter Mulbry of the USDA Agricultural Research Service. The work was carried out at the experimental dairy farm of the National Agricultural Laboratory, located in Beltsville, Maryland. Four ATS raceways, each 1 meter wide and 30 meters long, were constructed on the ground with the screens placed on landfill liner. Two raceways had a 1% slope and the other two had a 2% slope. Productivity and nutrient uptake data along with economic costs were assessed. Studies also demonstrated the utility of the harvested algal biomass as a fertilizer.

Oilgae – Home of Algal Energy

To order a copy of the report, visit - <https://secure.clixoo.com/purchase/oilgae/wwt/report.html>



## Sample Content: Aquaculture Industry

### Case Study

#### *Kent BioEnergy Facility near Mecca, CA*

The company now holds a variety of patents and exclusive licenses for aquaculture wastewater treatment systems, algae-based water recycling systems, and algae-based environmental remediation technology. It also has patents pending for making algae easier to harvest, methods for maintaining algae monocultures (ensuring that a pond has just one species of algae), and for genetically modifying algae to enhance algal production of valuable oils that can be used to make fuels.

## Sample Content: Chemical Industry

### Case Study : Chemfab Alkalies Ltd. Pondicherry, India

The factory uses ground water during processing at various stages to extract useful chemicals from crude sea salt. The effluent water that is discharged has a very high salinity and TDS. A team carried out research work on treatment of waste water employing various species of microalgae including a few freshwater as well as marine forms to remove nutrients and bring down TDS. Successful results were obtained with immobilized cells of micro- algae. Work is underway to extend this technique to field conditions.

#### *Examples of Benefits of Phycoremediation of Wastewater*

*(Based On Data from Implementation in the Alginate Industry)*

Cost parameter	Conventional Effluent Treatment	Phycoremediation	Annual cost benefit
Acidity - High levels of dissolved carbon dioxide	Neutralization with caustic soda	Algal treatment to absorb the acidic contents and neutralize the effluent	Rs. 50 lakhs spent for caustic soda annually is saved (100%).  The total cost for the utilities (labor / electricity etc) used in the operation is

### Oilgae – Home of Algal Energy

To order a copy of the report, visit - <https://secure.clixoo.com/purchase/oilgae/wwt/report.html>

			almost identical. At around Rs. 2 lakhs p.a. *
Sludge formation	Evaporation of effluents deposits sludge. That needs to be buried in a land fill. About 290 tonnes of sludge produced annually.	Algal remediation produces a nutrient rich, commercially valuable fertilizer that is highly demanded in the market.  There is no residual sludge.	The sludge disposal used to cost an estimated Rs. 3 lakhs annually. This cost is saved. *  Additionally revenues from the sale of algal biomass fertilizer.
Structures and space.	11,000 Sq m of masonry tank for evaporating the effluent	3000 sq m of tank for containing and evaporating the effluent.	About 75% of the effluent treatment facility space is released. This very valuable real estate structural space is now being used for other productive uses.

### Sample Content: Advantages of Industrial Wastewater Treatment Using Algae

- Low energy requirement
- Cost effective
- Removes heavy metals
- Biomass produced
- CO<sub>2</sub> fixed

### Sample Content: Research & Experiments

#### Continuous microalgae cultivation in aquaculture wastewater by a membrane photo-bioreactor for biomass production and nutrients removal

In photo-bioreactors, a high concentration of microalgae and high loading of nutrients is necessary to maintain a high growth rate of microalgae. However in industries such as aquaculturing, the wastewater tends to be low on nutrients. In order to use such media that are low on nutrients, membrane photo-bioreactors have been developed. Confining microalgae by membranes prevents washout of biomass. Using a continuous cultivation process allows large supply volumes of waste water that can offset the lower concentrations of nutrients. In the following study performed at the Zhejiang Ocean University in China, continuous microalgae cultivation in a membrane photo-bioreactor (MPBR) shows good

**Oilgae – Home of Algal Energy**

To order a copy of the report, visit - <https://secure.clixoo.com/purchase/oilgae/wwt/report.html>

performance in biomass production and nutrient removal from low strength aquaculture wastewater. For such diluted wastewaters, MBPR is a promising advancement in treatment technologies and for concentrated microalgae cultivation.

*Comparison of the operation conditions and nutrients removal performance of the treatment of aquaculture wastewater with the previous studies.*

Study	Nutrients concentration in influent (mg L <sup>-1</sup> )		Treatment method	HRT	Nutrients reduction (%)	
	Nitrogen <sup>a</sup>	Phosphorus <sup>b</sup>			Nitrogen	Phosphorus
This study	6.81	0.42	Microalgae cultivation in MPBR	1.0 d	86.1	82.7
Guo et al. (2013)	2.39	0.21 <sup>d</sup>	Batch cultivation of microalgae	14 d	87–95	98–99
Nasir et al. (2015)	0.91 <sup>c</sup>	2.6 <sup>d</sup>	Batch cultivation of microalgae	14 d	72.1–94.3	63.1–92.2
Shi et al. (2011)	13.9	0.08	Constructed wetland	0.4–1.0 d	66.8	23.8
Klomjek and Nitorisavut (2005)	19.5–24.3 <sup>c</sup>	7.8–8.8	Constructed wetland	2.0–5.0 d	18.0–65.3	12.2–40.5
Sharrer et al. (2007)	50.7–68.4	19.2–57.2	Membrane biological reactor (MBR)	40.8 h	91.8–95.5	65.2–96.1

<sup>a</sup> Total nitrogen (TN) unless specified.

<sup>b</sup> Total phosphorus (TP) unless specified.

<sup>c</sup> Ammonia nitrogen (NH<sub>3</sub>-N).

<sup>d</sup> Orthophosphate phosphorus (PO<sub>4</sub><sup>3-</sup>-P).

## Selection of native Tunisian microalgae for simultaneous wastewater treatment and biofuel production

In order to achieve maximum benefits from microalgae cultivation, selection of appropriate strains that possess good wastewater tolerance is an essential criterion. Naturally adapted microalgae isolated from waste water treatment plants or extreme environments have been shown to exhibit better bioremediation and better growth in waste-water conditions. Researchers from the University of Sfax in Tunisia and the University of Almería, from Spain looked for natural strains of microalgae in existing waste water treatment facilities in Tunisia. They isolated a native strain of *Scenedesmus sp.* that had higher biomass production along with better efficiency of waste water treatment.

At a dilution rate of 0.6litre/day, maximum productivity of 0.9g/l day, COD reduction from 1180mg/l to 73.9 mg/l, nitrogen removal rate of 34.6mg N/l day and a phosphorus removal rate of 12.7 mg/l day were achieved. The lipid content was 14.8% and 54% of total fatty acids were saturated and mono-saturated fatty acids.

We have provided detailed descriptions and results for many more research attempts in the field of algae-based industrial wastewater treatment.

**Oilgae – Home of Algal Energy**

To order a copy of the report, visit - <https://secure.clixoo.com/purchase/oilgae/wwt/report.html>

# 4 Nutrient Requirements of Algae

This chapter provides a better understanding of nutrient requirements of algae and enables the reader to decide on the additional nutrients to be added for growing algae in wastewater.

- Introduction
- Carbon Requirements
- Nitrogen Requirements
- Phosphorus Requirements
- Requirements of Micronutrients

## Sample Content: Phosphorus Requirements

Phosphorus is a key nutrient element required for normal growth of algae. Although the concentration of organic phosphate in natural waters often exceeds that of inorganic phosphate, the major form in which micro-algal cells acquire phosphorus is as inorganic phosphate. Phosphorus is rarely limiting in wastewater derived from animal husbandry, however, nitrogen may become limiting. The optimum N: P ratio for phytoplankton growth generally is about 15: 1, and high ratios (i.e., about 30: 1) suggest P limitation, whereas low ratios of about 5: 1 suggest N- limitation (Darley, 1982).

**Oilgae – Home of Algal Energy**

To order a copy of the report, visit - <https://secure.clixoo.com/purchase/oilgae/wwt/report.html>

# 5 Harvesting of Algae from HRAP

This chapter provides a thorough understanding of various methods of harvesting employed for algae grown in wastewater.

- Introduction
- Sedimentation
- Flotation
  - Dissolved Air Flotation
  - Suspended Air Flotation
- Filtration
- Chemical Precipitation

## Introduction

Choosing a harvesting method depends mainly on the types of algae species that are growing in the wastewater treatment system. Species control in wastewater treatment systems will greatly aid in algal harvesting by algae which is filamentous or settles easily (Benemann et al 1980).

Examples of microalgae wastewater systems in Northern California and their harvesting methods are listed below

Location	Area (ha)	System Design	Algae Harvest
Napa	140	Deep Ponds	Harvest Flocculants
St. Helena	8	Raceway (2 ha)	Terminal Settling ponds
Sunnyvale	180	Deep Ponds	Harvest Flocculants
Hollister	13	Raceway (5 ha)	Land Disposal

Source:

<http://www.osti.gov/bridge/servlets/purl/137315-0uSjuX/webviewable/137315.pdf>

**Oilgae – Home of Algal Energy**

To order a copy of the report, visit - <https://secure.clixoo.com/purchase/oilgae/wwt/report.html>

# 6 End Uses of Algae Grown in Wastewater

This chapter lists the various end uses of algae produced from wastewater and provides detailed inputs on the market size and market price for each product.

## 6.1 Introduction

## 6.2 Various End Uses Considered For Algae Grown In Wastewater

## 6.3 Fuel Applications of Wastewater Grown Algae

## 6.4 Non-Fuel Applications of Wastewater Grown Algae

### Sample Content: Fuel Applications of Wastewater Grown Algae

Algae can be used to produce many types of biofuels. Among them:

- Biodiesel, by transesterification of algal oil.
- Bioethanol ( $C_2H_6O$ ) by fermentation and distillation of sugars
- Biobutanol ( $C_4H_{10}O$ ), which can be produced from the green waste left over from the oil extraction.
- SVO (Straight Vegetable Oil), which is algal oil directly used as a fuel. It requires modifications to a normal diesel engine.
- Biogas (methane) production was the focus of most of the early work in biofuels from microalgae, when these were considered mainly for their applications in wastewater treatment.
- Other hydrocarbon fuel variants, such as JP-8 fuel, gasoline, etc.

### Sample Content: Non-fuel Applications of Wastewater Grown Algae

A summary list of non-fuel applications of wastewater grown algae:

- Animal & Fish Feed - Shrimp feed, Shellfish Diet, Marine Fish Larvae Cultivation
- Chemicals & Fertilizer
- Biopolymers & Bioplastics
- Paints, Dyes and Colorants
- Lubricants
- Pollution Control
- $CO_2$  Sequestration
- Uranium/Plutonium Sequestration
- Fertilizer Runoff Reclamation
- Sewage & Wastewater Treatment

The report provides details on the market size and uses for each product listed above.

Oilgae – Home of Algal Energy

To order a copy of the report, visit - <https://secure.clixoo.com/purchase/oilgae/wwt/report.html>

## Sample Content: Biopolymers & Bioplastics

Typically, long chain polymers, present in the algae lipids are used for making bioplastics.

### ***Market Size & Growth***

According to a report from the consulting firm Helmut Kaiser, the market for bioplastics is already significant, having reached over US\$1 billion in 2007; it is expected to be worth over US\$10 billion by 2020. A number of companies are entering and investing in the market with new applications and innovations in the automotive and electronics industry leading the market boom. Over 500 bioplastics processing companies are operating today, with more than 5000 expected by 2020.

- Fast growing market, with a projected market size of \$10 billion by 2020.
- World market expected to grow 30% per year for next decade
- Bioplastics could eventually capture 10%-20% of overall plastic market

**Oilgae – Home of Algal Energy**

To order a copy of the report, visit - <https://secure.clixoo.com/purchase/oilgae/wwt/report.html>

# 7 Challenges Associated with Growing Algae in Wastewater

This chapter presents a complete list of challenges associated with algae-based wastewater treatment systems

## 7.1 Introduction

## 7.2 Factors Affecting Microalgal Culture in HRAP & WSP

## 7.3 Challenges Associated With Algae-based Wastewater Treatment Systems

### Sample Content: Challenges Associated With Algae-based Wastewater Treatment Systems

Algae-based wastewater treatment technology is suited for tropical countries where the temperature is warmer and sunlight is optimum. Environmental factors play a major role in algae cultivation. Maintenance of optimum temperature and lighting in algae ponds are difficult. Apart from these environmental factors, there are a number of biological problems and operational problems can arise in the mass cultivation of microalgae using wastewater. These include contamination and grazing. Control measures for avoiding contamination by bacteria and other algal species are sterilization and ultra-filtration of the culture medium. Grazing by protozoans and diseases like fungi can eventually be treated chemically.

Some of the key challenges are:

- Land requirements
- Light requirements
- Temperature
- Rainfall
- Mixing
- Harvesting
- Contamination
- Grazing
- Oxygen Depletion
- Other Challenges

Detailed inputs for all the above challenges are given in the report.

**Oilgae – Home of Algal Energy**

To order a copy of the report, visit - <https://secure.clixoo.com/purchase/oilgae/wwt/report.html>



# 8 Companies in the Algae - based Wastewater Industry

This chapter lists the companies in algae-based wastewater treatment systems and their profiles

- 8.1 Introduction
- 8.2 Company Profiles

## Sample Content:Company Profiles

### Sunrise Ridge Algae, Inc.

*Main line of activity:* Production of Biofuels from Algae

*Headquartered at:* Austin (TX), USA

SunriseRidge Algae is a Texas, USA corporation engaged in research, development and commercialization of algae biomass technology for reduction of water and greenhouse gas pollutants and production of renewable fuel feedstocks and animal feeds.

Sunrise Ridge was founded in Houston in 2006 and has algae-growing operations in Austin, Texas, at the City of Austin's Hornsby Bend wastewater sludge treatment plant.

### *Process & Technology*

The company has demonstrated that algae can remove nutrient pollutants from the wastewater. The company is working to integrate wastewater treatment, carbon dioxide consumption and bio-oil production to create a highly efficient process for cleaning up pollution while generating revenues from biooleum sales. This process may be interesting to municipal utilities, industrial companies and agricultural firms, since it helps solve many of their pollution issues.

Sunrise Ridge Algae's pilot facility uses clear plastic bags to grow algae, fed with municipal wastewater and CO<sub>2</sub>. A circulation system (inset top) is used for churning the wastewater. The harvested algae are then dewatered (inset bottom). However, the systems face high infrastructure costs, and an indoor system may require artificial lighting, which increases energy costs. A key issue at Sunrise Ridge is lowering the costs of the greenhouses while maintaining a high production of algae, insuring a return on capital invested in the system. Maintaining a high production rate is dependent on selecting algae strains with high oil content

**Oilgae – Home of Algal Energy**

To order a copy of the report, visit - <https://secure.clixoo.com/purchase/oilgae/wwt/report.html>

that grow well in the greenhouse environment. Oil content can vary from 4 to 50 percent by weight, depending on the species and growing conditions.

CO<sub>2</sub> is created at many wastewater treatment plants when sludge is incinerated or processed in an anaerobic digester to produce biogas (a mixture of methane and CO<sub>2</sub>). Sunrise Ridge takes CO<sub>2</sub> from the plant's flue stacks and bubbles it through the plastic greenhouses. The enclosed greenhouses maintain desired CO<sub>2</sub> concentrations by preventing the gas from bubbling out into the atmosphere. In initial testing, algae reduced nitrate levels in the wastewater to as low as two part per million.

### *Highlights*

- With a goal to produce biodiesel, ethanol and animal feed supplements, the company has a focus on using wastewater to grow algae.

<http://www.sunrise-ridge.com>

### **Algae tech International**

*Main line of activity:* High value products from algae

*Headquartered at:* Malaysia

Algaetech has started research in algae since 2004 and has been awarded many grants by the Malaysian Government for its algal research projects into renewable energy and high value functional foods including Astaxantin. The Company is currently developing a pilot project of bio-remediation using algae integrated treatment system.

The project focuses on the additional treatment and polishing of effluent from Indah Water Konsortium (IWK) waste facility and at the same time will reduce the cost of running the existing plant and the production of a biomass (e.g. algae), and the potential to convert this biomass into renewable biogas with the microalgae biomass as a co-feedstock. Algae tech International aims to create an overall saving for electrical uses for pumping the influent at WTP of at least 50% – 70% after a few months of operation.

### **Projects**

- Research & Development of Algae for functional food and biofuel;
- Consultancy in CO<sub>2</sub> Sequestration, Carbon Credit Management and Integrated Renewable Energy Plant combined with algae cultivation and production;
- Primary production of high value products including Spirulina tablets and anti oxidants;

<http://algaetech.com.my/v1/about-us/>

### **Oilgae – Home of Algal Energy**

To order a copy of the report, visit - <https://secure.clixoo.com/purchase/oilgae/wwt/report.html>

# 9

## Algae Cultivation in Wastewater – Q&A

This chapter provides answers to specific questions that are frequently asked on some of the critical aspects in algae-based wastewater treatment.

### Is it possible to combine wastewater from different industries and treat them with algae?

Yes, it is possible to use different waste such as piggery waste, poultry waste and aquaculture waste and then do a primary treatment to treat it with sludge. A research effort from researchers from SARDI Aquatic Sciences Centre, South Australian Research Development Institute (2003) revealed that a combination of poultry waste, piggery waste and aquaculture wastes are excellent sources for algae wastewater treatment.

### Will toxins affect algal growth in wastewater?

Yes, certain toxins can severely affect algae growth in wastewater. Consider the following experiment: An experiment determined the toxic effect of four metals, cadmium (Cd), copper (Cu), mercury (Hg) and lead (Pb), on the tropical microalga *Tetraselmis chuii*. It evaluated the lethal effect daily, through the cellular count. In the control treatment (not exposed to any metal) the team observed an increase in cellular density. In all treatments exposed to metals, the team observed a decrease in cellular density, which accelerated in 48 h, after which it became less pronounced. The metal that caused the most lethal effect was Pb, which killed 50% of the microalgal population at a concentration of 0.40 mg/l. This concentration was 3 times lower than that of mercury and 13 times lower than those of cadmium and copper.

*Content of Selected Heavy Metals in a Sample Wastewater Treatment Plant*

Metal	Influent (mg.l <sup>-1</sup> )		Effluent (mg.l <sup>-1</sup> )		RE* (%)	Solid Fraction (mg.kg <sup>-1</sup> dm)	
	Min-max	Mean ± SD	Min-max	Mean ± SD		Min-max	Mean ± SD
Cd	0.01-0.80	0.29 ± 0.31	0.006-0.01	0.008±0.002	97.3	0.6-15.2	7.45±5.90
Pb	0.02-1.70	0.66 ± 0.71	0.02-0.23	0.125±0.082	80.3	3.8-45.2	35.38±15.68
Cu	0.50-2.10	1.22 ± 0.64	0.03-0.10	0.067±0.035	94.5	37.5-45.2	41.40±2.42
Zn	0.32-14.5	7.15 ± 5.86	0.12-0.44	0.27±0.12	96.2	201.2-310.2	252.40-34.96

\*: Removal efficiency

Source: <http://www.ramiran.net/doc05/Folia/Vargova.pdf>

**Oilgae – Home of Algal Energy**

To order a copy of the report, visit - <https://secure.clixoo.com/purchase/oilgae/wwt/report.html>

**Other questions for which answers are provided in this chapter:**

1. At which stage of wastewater treatment are algae introduced?
2. What are the natural microfloras of microalgae present in the wastewater?
3. Worldwide, which are the regions that are most suited to algae-based waste water treatment?
4. Is it possible to grow macro algae in wastewater for bioremediation?
5. Is it possible to treat acidic effluents with algae?
6. Which are the algal strains suitable for basic effluents?
7. As wastewater already contains nutrients, is there any need for additional nutrients for algae cultivation in wastewater?
8. Are there any algae predators present in wastewater?
9. What are the monitoring techniques used in algae wastewater treatment?
10. To what extent are algae capable of reducing heavy metals from wastewater?
11. What is the potential of algae wastewater treatment for anaerobic digestion effluents?
12. Is it possible to use algae to treat organic pollutants like phenolic wastes? Which algalstrains are suitable to treat wastewater with high phenolic content?
13. What are the constraints in using wastewater grown algae for animal feed?

# 10

## References

This chapter lists the related organizations and universities to enabling researchers and entrepreneurs to get in touch with them for industrial collaborations

### 10.1 Algal Biomass Organizations

### 10.2 Universities in Algae-based Wastewater Treatment Research

### 10.3 Wastewater Treatment - Current Trends

#### Sample Content:

#### 10.2 Universities in Algae-based Wastewater Treatment Research

**The University of Vaasa (Finland)**, along with the Pätt wastewater treatment plant have started **TransAlgae**, a new algae research project that studies utilization of waste flows to produce micro- and macro-algae.

Other partners in this three-year project are: Novia University of Applied Sciences from Finland; Swedish University of Agricultural Sciences (Umeå), Mid Sweden University (Sundsvall), Nattviken Invest AB and Biofuel Region Bfr AB from Sweden; and Norwegian Institute of Bioeconomy Research (NIBIO) from Norway.

A network of small and medium-sized stakeholders such as wastewater treatment plants, biogas producers, dairy farms, power plants, and pulp and paper industry plants are expected to be brought together as a result of this project.

The Trans Algae project has received funding from the EU's Botnia-Atlantica programme. Project funding totals EUR 2.2 million.

**Oilgae – Home of Algal Energy**

To order a copy of the report, visit - <https://secure.clixoo.com/purchase/oilgae/wwt/report.html>

## 11. Culture Collection Centers

### 11.1 Introduction

### 11.2 List of Algae Culture Collection Centre

Country	Centre	Mode of ordering
Australia	CSIRO Microalgae Research Centre <a href="http://www.cmar.csiro.au/microalgae/supply.html">http://www.cmar.csiro.au/microalgae/supply.html</a>	Mail
Canada	University Of Toronto Culture Collection <a href="http://www.botany.utoronto.ca/utcc/">http://www.botany.utoronto.ca/utcc/</a>	Online and Phone
	Canadian Centre For Culture Collection <a href="http://www.botany.ubc.ca/cccm/">http://www.botany.ubc.ca/cccm/</a>	Mail, Phone
CzechRepublic	Culture Collection of Algae of CharlesUniversity of Prague <a href="http://botany.natur.cuni.cz/algo/caup.html">http://botany.natur.cuni.cz/algo/caup.html</a>	Mail, Phone
	Culture Collection of Algal Laboratory ( CCALA ) Institute of Botany, Academy of Sciences of the CzechRepublic <a href="http://www.butbn.cas.cz">www.butbn.cas.cz</a>	Online

Oilgae – Home of Algal Energy

To order a copy of the report, visit - <https://secure.clixoo.com/purchase/oilgae/wwt/report.html>

## Price of the Wastewater Treatment Using Algae Report

### The price of the Wastewater Treatment Using Algae Report

- **Companies /Entrepreneurs - US\$ 700**

\* People who wish to procure the report under this option are requested to send an email to [muthukrishnan@eai.in](mailto:muthukrishnan@eai.in) with their details. Our team will get in touch with you soon

You can purchase the report using a credit card from here -  
<https://secure.clixoo.com/purchase/oilgae/wwt/report.html>

To know more about the report, visit -  
[http://www.oilgae.com/ref/report/wastewater\\_treatment/wastewater\\_treatment.html](http://www.oilgae.com/ref/report/wastewater_treatment/wastewater_treatment.html)

If you are interested in purchasing the report, please send a note to **Muthukrishnan**—  
email: [muthukrishnan@eai.in](mailto:muthukrishnan@eai.in) or [enquiry@oilgae.com](mailto:enquiry@oilgae.com) Mobile: +91-99529 10083 (India)